

Replacement Guide Heating

Wilo Circulators
for Heating and
Secondary Hot Water Circulation

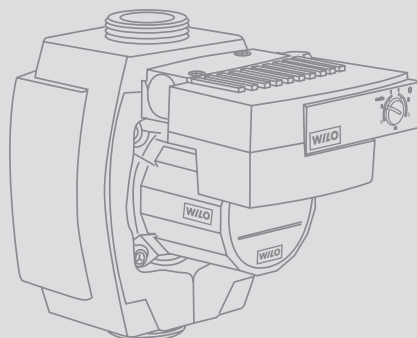
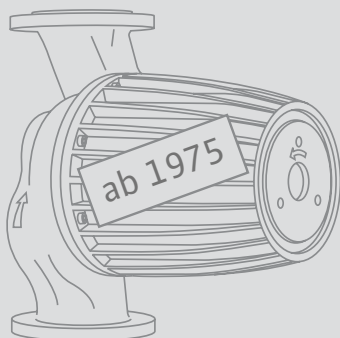

September 2006

Energy efficiency class A.
Also for one- and two-family homes.
Up to 80 % power savings.*
Highly efficient.

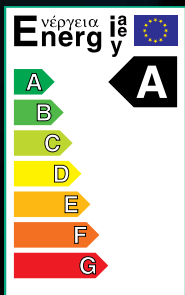

*compared to uncontrolled heating pumps.

High-efficiency pumps Wilo-Stratos and Wilo-Stratos ECO.

The Wilo-Stratos-ECO is the world's first high-efficiency pump. And it is the reference for the energy label. Allowing power savings of up to 80 %*, it set the standard for the energy efficiency class A as early as in 2001. The Wilo-Stratos ECO offers this state-of-the-art technology now also for one- and two-family homes. Ingenious? We call it Pumpen Intelligenz.



WILO
Pumpen Intelligenz.

www.wilo.com

Wilo Replacement Guide Heating

Notes	2
Energy efficiency classes	3

Heating

Modular Concept for Wilo-TOP-V pumps	6
Wilo	7 – 13

Grundfos	14 – 26
-----------------	----------------

KSB	27 – 35
------------	----------------

Secondary hot water circulation

Wilo	36 – 37
-------------	----------------

Grundfos	38 – 41
-----------------	----------------

KSB	42
------------	-----------

Adapters	43 – 45
Technical notes	46 – 53
System optimisation	54 – 55
Name plates	56 – 58

Notes

The quick selection of a new Wilo pump is guaranteed by:

- the **make overview** for the replacement of circulating pumps, sorted by single-head and twin-head pumps for heating as well as secondary hot water circulating pumps
- **detailed explanations and notes for the installation** in the Technical Appendix (fault reasons, EnEV etc.)

Optimisation

- Replacing a pump always offers the opportunity to adapt and re-determine the pump performance in consideration of the modifications which have been done at and in the building.
- High-efficiency pumps or energy-saving pumps can avoid noise disturbances which may occur due to installed thermostatic valves and therefore increasing pump pressure when valves are closing.
- Low heat demand thanks to heat insulation of the building. The formerly high pump performance is not needed any longer. Experience shows that smaller pumps are fully sufficient and even reduce power consumption.
- Profit from the simplified new determination of the pump performance. It is described in the "System optimisation" chapter.

Note:

The German Energy Saving Ordinance

- (EnEV §12, Paragraph 3) demands in heating installations from 25 kW central heating capacity onwards always a pump with capacity control, both in old installations and in new buildings (single-head and twin-head pumps).
- This basically requires that all flanged pumps are equipped with a pump capacity control.
- With the high-efficiency pumps and the energy-saving pumps, Wilo offers the ideal concept to meet this requirement.
- The compact design with integrated control directly at the pump makes additional switchgears unnecessary.

Energy efficiency classes

- Europe's leading heating pump manufacturers have committed themselves to a uniform labelling of the energy consumption.
- The labelling is identical with the one on refrigerators and other household appliances.
- As early as in 2001 we set the standard for the energy efficiency class A by introducing the Wilo-Stratos.
- The Wilo-Stratos and Wilo-Stratos ECO are labelled with the energy efficiency class A and reach power savings of up to 80% compared with uncontrolled heating pumps!

Selection criteria

- This replacement guide includes pump types from construction year 1975 onwards.
Wilo always offers 3 solutions for heating pumps:
- **High-efficiency pump** (infinitely variable), energy efficiency class: A
- **Energy-saving pump** (infinitely variable)
- **Standard pump** (3 or 4 stages)
- The technical selection criteria of the old pump are:
- **The installation length/nominal width** of the Wilo pump corresponds **if possible** to the dimensions of the pump to be replaced.
- When replacing flanged pumps up to a nominal width of DN 65, the dimensions of the counterflanges have to be checked (different flange sizes between versions PN 6 and PN 10). Combination flanges PN 6/10 must not be connected to other combination flanges.
- In the event that the installation length of the Wilo pump is **shorter** than that of the pump to be replaced, **adapters and flange adapters** are available to compensate the length. Possibly the motor with the terminal box needs to be turned by 90°.
- The **hydraulic flow rate of the Wilo pump** (max. curve) is, **if possible, equal** to the flow rate in the back area of the pump curve.

Energy efficiency classes

EEl Classification

In line with the Kyoto protocol the European governments in particular aim at considerably reducing CO₂ emissions. An essential requirement is the energy labelling of particular energy-relevant household appliances like washing machines and refrigerators, in order to make it easier for the end user to decide in favour of energy-saving appliances.

As heating circulating pumps have a long lifetime and therefore are one of the biggest power consumers in households, Europe's leading heating pump manufacturers have committed themselves on a voluntary basis to label heating pumps with an energy label, too. Thus users and end consumers are able to determine by means of a known classification system whether a heating circulating pump is particularly energy-efficient.

The energy efficiency of heating pumps is classified by means of a metrological method which delivers the energy efficiency index, the EEI. The smaller the EEI, the less electrical energy the pumps consumes and the better is the energy classification.

Energy class	Energy efficiency index
A	$EEI < 0.4$
B	$0.4 \leq EEI < 0.6$
C	$0.6 \leq EEI < 0.8$
D	$0.8 \leq EEI < 1.0$
S	$1.0 \leq EEI < 1.2$
F	$1.2 \leq EEI < 1.4$
G	$1.4 \leq EEI$

Tab.: Classification of the energy efficiency index in 7 different energy efficiency classes

The following tables show the energy classes for all heating pumps which have to be labelled; the energy classes can be seen from the energy label on the packaging. Just like on household appliances, the letter A is the best and G is the worst energy class.

When comparing hydraulically similar pumps with different energy classes, you can see that there is a difference of approx. 22 per cent points in the energy demand between two neighbouring energy classes. A pump with energy class A therefore demands on average only 33% of the electrical energy which a pump of class D needs.

Although the energetic requirements on a pump of class A are very high, the complete application range from one-family homes to large buildings can be covered by high-efficiency pumps of energy efficiency class A.

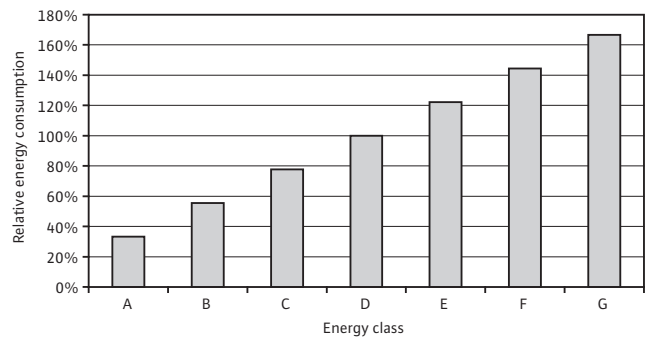

Fig.: Comparison of the energy consumption of pumps with identical hydraulic output

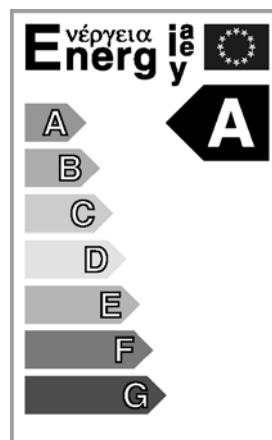

Fig.: Energy label for heating circulating pumps, Example: Energy class A

Wilo Replacement Guide Heating

Energy efficiency classes

EEl-Classification – Single-head pumps/Twin-head pumps (Field of application: one/two-family house)

Nominal dia.	Wilo-Stratos ECO...	EEl-Class	Wilo-Star-E... (EasyStar)	EEl-Class	Wilo-Star-RS... (ClassicStar)	EEl-Class	Wilo-Star-RSD... (ClassicStar)	EEl-Class
DN 15 (Rp ½)	–	–	15/1-3	–	15/4	B	–	–
	–	–	15/1-5	–	15/6	C	–	–
DN 25 (Rp 1)	25/1-3	A	25/1-3	B	25/2	C	–	–
	25/1-5	A	25/1-5	B	25/4	B	–	–
	–	–	–	–	25/6	C	–	–
DN 30 (Rp 1 ¼)	30/1-3	A	30/1-3	B	30/2	C	30/4	D
	30/1-5	A	30/1-5	B	30/4	B	30/6	D

EEl-Classification – Single-head pumps (Fields of application: multi-family homes, commercial applications)

Nominal dia.	Wilo-Stratos...	EEl-Class	Wilo-TOP-E...	EEl-Class	Wilo-TOP-S...	EEl-Class	Wilo-RP/P...	EEl-Class
DN 25 (Rp 1)	25/1-6	A	25/1-7	C	25/5 EM/DM	D/D	RP 25/80 r EM/DM	G/F
	25/1-8	A	–	–	25/7 EM/DM	D/D	RP 25/100 r EM/DM	F/E
	–	–	–	–	25/10 EM/DM	D/D	–	–
DN 30 (Rp 1 ¼)	30/1-6	A	30/1-7	C	30/4 EM/DM	D/D	RP 30/80 r EM/DM	G/F
	30/1-8	A	30/1-10	C	30/5 EM/DM	D/D	RP 30/100 r EM/DM	F/F
	30/1-12	A	–	–	30/7 EM/DM	D/D	–	–
	–	–	–	–	30/10 EM/DM	D/D	–	–
DN 32	32/1-12	A	–	–	–	–	–	–
DN 40	40/1-4	A	40/1-4	C	40/4 EM/DM	D/D	P 40/100 r EM/DM	F/D
	40/1-8	A	40/1-10	B	40/7 EM/DM	D/C	P 40/160 r	S
	40/1-12	A	–	–	40/10 EM/DM	D/C	–	–
	–	–	–	–	40/15 EM/DM	D/D	–	–
DN 50	50/1-8	A	50/1-6	C	50/4 EM/DM	D/D	P 50/125 r	D
	50/1-9	A	50/1-7	B	50/7 EM/DM	E/D	P 50/160 r	S
	50/1-12	A	50/1-10	B	50/10 EM/DM	D/C	P 50/250 r	S
	–	–	–	–	50/15	C	–	–
DN 65	65/1-9	A	65/1-10	B	65/7 EM/DM	F/D	P 65/125 r	D
	65/1-12	A	–	–	65/10 EM/DM	F/D	P 65/160 r	D
	–	–	–	–	65/13	C	P 65/250 r	S
	–	–	–	–	65/15	C	–	–
DN 80	80/1-12	A	80/1-10	B	80/7 EM/DM	F/D	P 80/125 r	D
	–	–	–	–	80/10	D	P 80/160 r	C
	–	–	–	–	–	–	P 80/250 r	S
DN 100	100/1-12	A	100/1-10	B	100/10	D	P 100/160 r	S
	–	–	–	–	–	–	P 100/200 r	S

Energy efficiency classes

EEI-Classification – Single-head pumps (Fields of application: multi-family homes, commercial applications) (continued)

Nominal dia.	Wilo-TOP-D...	EEI- Class
DN 30 (Rp 1 ¼)	30EM/DM	G/F
DN 40	40EM/DM	E/E
DN 50	50EM/DM	E/E
DN 65	65EM/DM	E/E
DN 80	80EM/DM	E/E
DN 100	100EM/DM	E/E
DN 125	125	D

EEI-Classification – Twin-head pumps (Fields of application: multi-family homes, commercial applications)

Nominal dia.	Wilo-Stratos-D...	EEI-Class	Wilo-TOP-ED...	EEI-Class	Wilo-TOP-SD...	EEI-Class	Wilo-DOP...	EEI-Class
DN 30 (Rp 1 ¼)	–	–	–	–	30/5 EM/DM	D/D	–	–
DN 32	32/1-8	A	32/1-7	C	32/7 EM/DM	E/D	–	–
	32/1-12	A	–	–	–	–	–	–
DN 40	40/1-8	A	40/1-7	C	40/3 EM/DM	E/D	40/100 r EM/DM	F/E
	40/1-12	A	40/1-10	B	40/7 EM/DM	D/D	40/160 r	F
	–	–	–	–	40/10 EM/DM	E/C	–	–
	–	–	–	–	40/15 EM/DM	E/D	–	–
DN 50	50/1-8	A	50/1-6	C	50/7 EM/DM	F/C	50/100 r	D
	50/1-12	A	50/1-7	B	50/10 EM/DM	E/D	50/160 r	S
	–	–	50/1-10	C	50/15	D	–	–
DN 65	65/1-12	A	65/1-10	B	65/10 EM/DM	F/D	65/125 r	D
	–	–	–	–	65/13	D	65/160 r	D
	–	–	–	–	65/15	D	–	–
DN 80	80/1-12	A	80/1-10	B	80/10	D	80/125 r	D
	–	–	–	–	80/7 single-phase motor	F	80/160 r	S
DN 100	–	–	–	–	–	–	100/160 r	D

Wilo Replacement Guide Heating

Modular concept for Wilo-TOP-V pumps

Wilo-TOP-EV				
Type	Overall length l_0 mm	Nominal width DN	Connection 50 Hz	Pressure stage PN
TOP-EV 25/1-7	180 (280)	Rp 1	1 ~	10
TOP-EV 30/1-7	180 (280)	Rp 1¼	1 ~	10
TOP-EV 40/1-4	250	DN 40	1 ~	6/10
TOP-EV 50/1-6	280	DN 50	1 ~	6/10
TOP-EV 65/1-10	400	DN 65	1 ~	6/10

Wilo-Motor-Module (MOT-E)	
Type	Connection 50 Hz
MOT-E 25/1-7	1 ~
MOT-E 30/1-7	1 ~
MOT-E 40/1-4	1 ~
MOT-E 50/1-6	1 ~
MOT-E 65/1-10	1 ~

Wilo-TOP-SV				
Type	Overall length l_0 mm	Nominal width DN	Connection 50 Hz	Pressure stage PN
TOP-SV 25/7	180 (280)	Rp 1	1 ~	10
			3 ~	10
TOP-SV 30/7	180 (280)	Rp 1¼	1 ~	10
			3 ~	10
TOP-SV 40/4	250	DN 40	1 ~	6/10
			3 ~	6/10
TOP-SV 50/6	280	DN 50	1 ~	6/10
			3 ~	6/10
TOP-SV 65/10	400	DN 65	3 ~	6/10

Wilo-Motor-Module (MOT-S)	
Type	Connection 50 Hz
MOT-S 25/7 EM	1 ~
MOT-S 25/7 DM	3 ~
MOT-S 30/7 EM	1 ~
MOT-S 30/7 DM	3 ~
MOT-S 40/4 EM	1 ~
MOT-S 40/4 DM	3 ~
MOT-S 50/6 EM	1 ~
MOT-S 50/6 DM	3 ~
MOT-S 65/10 DM	3 ~

Wilo-TOP-ZV				
Type	Overall length l_0 mm	Nominal width DN	Connection 50 Hz	Pressure stage PN
TOP-ZV 25/7	180	Rp 1	1~	10
			3~	10
TOP-ZV 30/7	180	Rp 1¼	1~	10
			3~	10
TOP-ZV 40/4	250	DN 40	1~	6/10
			3~	6/10
TOP-ZV 50/6	280	DN 50	1~	6/10
			3~	6/10
TOP-ZV 65/10	400	DN 65	3~	6/10

Wilo-Motor-Module (MOT-Z)	
Type	Connection 50 Hz
MOT-Z 25/7 EM	1 ~
MOT-Z 25/7 DM	3 ~
MOT-Z 30/7 EM	1 ~
MOT-Z 30/7 DM	3 ~
MOT-Z 40/4 EM	1 ~
MOT-Z 40/4 DM	3 ~
MOT-Z 50/6 EM	1 ~
MOT-Z 50/6 DM	3 ~
MOT-Z 65/10 DM	3 ~

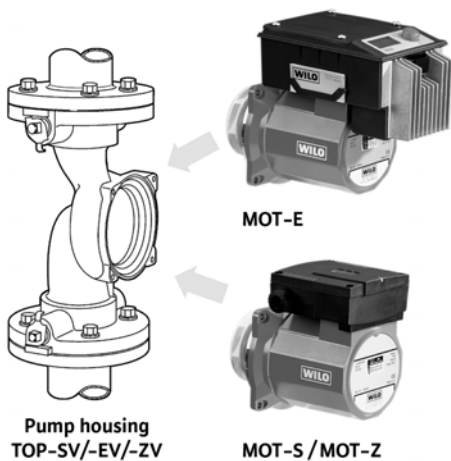

Wilo				Wilo – new											
Single-head pumps				High-efficiency pumps				Energy-saving pumps*)				Standard pumps*)			
				Infinitely variable, 1~230V, 50Hz Stratos $T_{min}: -10^{\circ}C/T_{max}: 110^{\circ}C$ Stratos ECO $T_{min}: +15^{\circ}C/T_{max}: 110^{\circ}C$				Infinitely variable, 1~230V, 50Hz $T_{max} = 95^{\circ}C$ or $110^{\circ}C$				1-/3-/4-stages 1~230V or 3~400V, 50Hz $T_{max} = 110^{\circ}C$ or $130^{\circ}C/140^{\circ}C$			
DN Type	PN	Motor	Overall length [mm]	Type	Motor	Overall length [mm]	Adapter/Remark	Type	Motor	Overall length [mm]	Adapter/Remark	Type	Motor	Overall length [mm]	Adapter/Remark
Rp ½ (Pump thread G 1)															
Star-E 15(20)/1-3	10	1	130	Stratos ECO 25/1-5-130	1	130	Mod.pipe	Star-E 15/1-3-130	1	130	-	-	-	-	-
Star-E 15(20)/1-5	10	1	130	Stratos ECO 25/1-5-130	1	130	Mod.pipe	Star-E 15/1-5-130	1	130	-	-	-	-	-
Star-RS 15/4-130	10	1	130	Stratos ECO 25/1-5-130	1	130	Mod.pipe	Star-E 15/1-3-130	1	130	-	Star-RS 15/4-130	1	130	-
Star-RS 15/6-130	10	1	130	Stratos ECO 25/1-5-130	1	130	Mod.pipe	Star-E 15/1-5-130	1	130	-	Star-RS 15/6-130	1	130	-
Rp ¾ (Pump thread G 1¼)															
P 20-1	10	1	140	Stratos ECO 25/1-5-130	1	130	Mod.pipe	Star-E 25/1-3	1	180	Mod.pipe	Star-RS 25/2	1	180	Mod.pipe
P 20-2	10	1	140	Stratos ECO 25/1-5	1	180	Mod.pipe	Star-E 25/1-3	1	180	Mod.pipe	Star-RS 25/2	1	180	Mod.pipe
S 20-1, S 20-2	6	1	140	Stratos ECO 25/1-5	1	180	Mod.pipe	Star-E 25/1-5	1	180	Mod.pipe	Star-RS 25/4	1	180	Mod.pipe
Rp 1 (Pump thread G 1½)															
P 25	10	1	180	Stratos ECO 25/1-5	1	180	-	Star-E 25/1-5	1	180	-	Star-RS 25/4	1	180	-
RP 25	6/10	1/3	180	Stratos ECO 25/1-5	1	180	-	Star-E 25/1-5	1	180	-	RP 25/80 r	1/3	180	-
RP 25-1	10	1/3	180	Stratos ECO 25/1-5	1	180	-	Star-E 25/1-5	1	180	-	RP 25/100 r	1/3	180	-
RP 25/100 v (r)	10	1/3	180	Stratos 25/1-6	1	180	-	-	-	-	-	RP 25/100 r	1/3	180	-
RP 25/60 r	10	1	180	Stratos ECO 25/1-3	1	180	-	Star-E 25/1-3	1	180	-	RP 25/60-2	1	180	-
RP 25/60-2	10	1	180	Stratos ECO 25/1-3	1	180	-	Star-E 25/1-3	1	180	-	RP 25/60-2	1	180	-
RP 25/80 v (r)	10	1/3	180	Stratos ECO 25/1-3	1	180	-	Star-E 25/1-3	1	180	-	RP 25/80 r	1/3	180	-
RS 25, RS 25-1 (v)	10	1	180	Stratos ECO 25/1-3	1	180	-	Star-E 25/1-3	1	180	-	Star-RS 25/4	1	180	-
RS 25-2	10	1	180	Stratos ECO 25/1-3	1	180	-	Star-E 25/1-3	1	180	-	Star-RS 25/2	1	180	-
RS 25/3 E (En)	10	1	180	Stratos ECO 25/1-3	1	180	-	Star-E 25/1-3	1	180	-	Star-RS 25/2	1	180	-
RS 25/50 (r) (RG)	10	1	180	Stratos ECO 25/1-5 (RG)	1	180	-	-	-	-	-	Star-RS 25/4 (RG)	1	180	-
RS 25/60 v (r) (RG)	10	1	180	Stratos ECO 25/1-5 (RG)	1	180	-	-	-	-	-	Star-RS 25/4 (RG)	1	180	-
RS 25/70 v (r) (RG)	10	1	180	Stratos ECO 25/1-5 (RG)	1	180	-	-	-	-	-	Star-RS 25/6 (RG)	1	180	-
RS 25/80 (v) (r)	10	1/3	180	Stratos 25/1-6	1	180	-	TOP-E 25/1-7	1	180	-	TOP-S 25/7	1/3	180	-
RSE 25, RS 25/2 E (En)	10	1	180	Stratos ECO 25/1-3	1	180	-	Star-E 25/1-3	1	180	-	-	-	-	-
S 25	6	1	180	Stratos ECO 25/1-5	1	180	-	Star-E 25/1-5	1	180	-	Star-RS 25/4	1	180	-
S 25-1	6	1	180	Stratos ECO 25/1-5	1	180	-	Star-E 25/1-5	1	180	-	Star-RS 25/6	1	180	-
S 30-1	6	1/3	180	Stratos 25/1-6	1	180	-	TOP-E 25/1-7	1	180	-	TOP-S 25/7	1/3	180	-
Star-E 25/1-3	10	1	180	Stratos ECO 25/1-3	1	180	-	Star-E 25/1-3	1	180	-	-	-	-	-
Star-E 25/1-3-130	10	1	130	Stratos ECO 25/1-5-130	1	130	-	Star-E 25/1-3-130	1	130	-	-	-	-	-
Star-E 25/1-5	10	1	180	Stratos ECO 25/1-5	1	180	-	Star-E 25/1-5	1	180	-	-	-	-	-
Star-E 25/1-5-130	10	1	130	Stratos ECO 25/1-5-130	1	130	-	Star-E 25/1-5-130	1	130	-	-	-	-	-
Star-E 25/2	10	1	180	Stratos ECO 25/1-3	1	180	-	Star-E 25/1-3	1	180	-	-	-	-	-
Star-EP 25/1-5	10	1	180	Stratos ECO 25/1-5	1	180	-	-	-	-	-	-	-	-	-
Star-EP 25/1-5 SSM	10	1	180	Stratos ECO 25/1-5-BMS	1	180	-	-	-	-	-	-	-	-	-
Star-RS 25/2	10	1	180	Stratos ECO 25/1-3	1	180	-	Star-E 25/1-3	1	180	-	Star-RS 25/2	1	180	-
Star-RS 25/4 (RG)	10	1	180	Stratos ECO 25/1-3	1	180	-	Star-E 25/1-3	1	180	-	Star-RS 25/4 (RG)	1	180	-
Star-RS 25/4-130	10	1	130	Stratos ECO 25/1-3	1	180	Mod.pipe	Star-E 25/1-3-130	1	130	-	Star-RS 25/4-130	1	130	-
Star-RS 25/6 (RG)	10	1	180	Stratos ECO 25/1-5 (RG)	1	180	-	Star-E 25/1-5	1	180	-	Star-RS 25/6 (RG)	1	180	-
Star-RS 25/6-130	10	1	180	Stratos ECO 25/1-5-130	1	130	-	Star-E 25/1-5-130	1	130	-	Star-RS 25/6-130	1	130	-
Stratos 25/1-6	10	1	180	Stratos 25/1-6	1	180	-	-	-	-	-	-	-	-	-
Stratos 25/1-8	10	1	180	Stratos 25/1-8	1	180	-	-	-	-	-	-	-	-	-
Stratos ECO 25/1-3	10	1	180	Stratos ECO 25/1-3	1	180	-	-	-	-	-	-	-	-	-



*) Energy efficiency class for each type see page 3-5

■ = Replacement pumps in accordance with EnEV (German Energy Saving Ordinance)

Observe current type (three-phase/single-phase) and nominal pressure of pump (PN 6/PN 10)! — 1 = 1~230 V single-phase, 3 = 3~400 V three-phase

Check separately whether existing switchgears can be used.

Wilo Replacement Guide Heating

Wilo				Wilo – new											
Single-head pumps				 High-efficiency pumps Infinitely variable, 1 ~ 230V, 50Hz Stratos $T_{min} = -10^{\circ}\text{C}/T_{max} = 110^{\circ}\text{C}$ Stratos ECO $T_{min} = +15^{\circ}\text{C}/T_{max} = 110^{\circ}\text{C}$				 Energy-saving pumps*) Infinitely variable, 1 ~ 230V, 50Hz $T_{max} = 95^{\circ}\text{C}$ or 110°C				 Standard pumps*) 1-/3-/4-stages 1 ~ 230V or 3 ~ 400V, 50Hz $T_{max} = 110^{\circ}\text{C}$ or $130^{\circ}\text{C}/140^{\circ}\text{C}$			
DN	Type	PN	Motor Overall length [mm]	Type	Motor Overall length [mm]	Adapter/Remark	Type	Motor Overall length [mm]	Adapter/Remark	Type	Motor Overall length [mm]	Adapter/Remark			
Rp 1 (Pump thread G 1½)															
	Stratos ECO 25/1-5	10	1 180	Stratos ECO 25/1-5	1 180	-									
	Stratos ECO 25/1-5 RG	10	1 180	Stratos ECO 25/1-5 RG	1 180	-									
	Stratos ECO 25/1-5-130	10	1 130	Stratos ECO 25/1-5-130	1 130	-									
	TOP-E 25/1-7	10	1 180	Stratos 25/1-8	1 180	-	TOP-E 25/1-7	1 180	-						
	TOP-S (RS) 25/7	10	1/3 180	Stratos 25/1-8	1 180	-	TOP-E 25/1-7	1 180	-	TOP-S 25/7	1/3 180	-			
	TOP-S 25/10	10	1/3 180	Stratos 30/1-12	1 180	Mod. pipe	TOP-E 30/1-10	1 180	Mod. pipe	TOP-S 25/10	1/3 180	-			
	TOP-S 25/5	10	1/3 180	Stratos 25/1-6	1 180	-	TOP-E 25/1-7	1 180	-	TOP-S 25/5	1/3 180	-			
Rp 1 (Pump thread G 1½) Venting pumps															
	RSL 25/70 r	10	1 180	Stratos ECO-L 25/1-5	1 180	-				Star-RSL 25/6	1 180	-			
	Star-EL 25/1-5	10	1 180	Stratos ECO-L 25/1-5	1 180	-									
	Star-RSL 25/6	10	1 180	Stratos ECO-L 25/1-5	1 180	-				Star-RSL 25/6	1 180	-			
Rp 1¼ (Pump thread G 2)															
	D 30	10	1/3 206	Stratos ECO 30/1-3	1 180	R9	Star-E 30/1-3	1 180	R9	TOP-D 30	1/3 180	R9			
	RP 30	6/10	1/3 180	-	-	-	Star-E 30/1-5	1 180	-	RP 30/80 r	1/3 180	-			
	RP 30-1	10	1/3 180	Stratos 30/1-6	1 180	-	Star-E 30/1-5	1 180	-	RP 30/100 r	1/3 180	-			
	RP 30/100 v (r)	10	1/3 180	Stratos 30/1-8	1 180	-	TOP-E 30/1-7	1 180	-	RP 30/100 r	1/3 180	-			
	RP 30/80 v (r)	10	1/3 180	Stratos ECO 30/1-5	-	-	Star-E 30/1-5	1 180	-	RP 30/80 r	1/3 180	-			
	RS 30, RS 30-1 (v)	10	1 180	Stratos ECO 30/1-5	1 180	-	Star-E 30/1-5	1 180	-	Star-RS 30/4	1 180	-			
	RS 30-2	10	1 180	Stratos ECO 30/1-3	1 180	-	Star-E 30/1-3	1 180	-	Star-RS 30/2	1 180	-			
	RS 30/100 v (r)	10	1/3 180	Stratos 30/1-12	1 180	-	TOP-E 30/1-10	1 180	-	TOP-S 30/10	1/3 180	-			
	RS 30/50 (r)	10	1 180	Stratos ECO 30/1-3	1 180	-	Star-E 30/1-3	1 180	-	Star-RS 30/2	1 180	-			
	RS 30/60 v (r)	10	1 180	Stratos ECO 30/1-3	1 180	-	Star-E 30/1-3	1 180	-	Star-RS 30/4	1 180	-			
	RS 30/70 v (r)	10	1 180	Stratos ECO 30/1-5	1 180	-	Star-E 30/1-5	1 180	-	Star-RS 30/6	1 180	-			
	RS 30/80 (v) (r)	10	1/3 180	Stratos 30/1-8	1 180	-	TOP-E 30/1-7	1 180	-	TOP-S 30/7	1/3 180	-			
	S 30	6	1/3 220	-	-	-				RP 30/100 r	1/3 180	R14			
	S 30/100	6/10	1/3 220	Stratos 30/1-12	1 180	R14	TOP-E 30/1-10	1 180	R14	TOP-S 30/10	1/3 180	R14			
	Star-E 30/1-3	10	1 180	Stratos ECO 30/1-3	1 180	-	Star-E 30/1-3	1 180	-						
	Star-E 30/1-5	10	1 180	Stratos ECO 30/1-5	1 180	-	Star-E 30/1-5	1 180	-						
	Star-EP 30/1-5	10	1 180	Stratos ECO 30/1-5	1 180	-									
	Star-EP 30/1-5 SSM	10	1 180	Stratos ECO 30/1-5-BMS	1 180	-									
	Star-RS 30/2	10	1 180	Stratos ECO 30/1-3	1 180	-	Star-E 30/1-3	1 180	-	Star-RS 30/2	1 180	-			
	Star-RS 30/4	10	1 180	Stratos ECO 30/1-3	1 180	-	Star-E 30/1-3	1 180	-	Star-RS 30/4	1 180	-			
	Star-RS 30/6	10	1 180	Stratos ECO 30/1-5	1 180	-	Star-E 30/1-5	1 180	-	Star-RS 30/6	1 180	-			
	Stratos 30/1-12	10	1 180	Stratos 30/1-12	1 180	-									
	Stratos 30/1-6	10	1 180	Stratos 30/1-6	1 180	-									
	Stratos 30/1-8	10	1 180	Stratos 30/1-8	1 180	-									

*) Energy efficiency class for each type see page 3-5

■ = Replacement pumps in accordance with EnEV (German Energy Saving Ordinance)

Observe current type (three-phase/single-phase) and nominal pressure of pump (PN 6/PN 10)! — 1 = 1 ~ 230 V single-phase, 3 = 3 ~ 400 V three-phase

Check separately whether existing switchgears can be used.

Wilo				Wilo – new											
Single-head pumps				High-efficiency pumps				Energy-saving pumps*)				Standard pumps*)			
				Infinitely variable, 1~230V, 50Hz Stratos T _{min} : -10°C/T _{max} : 110°C Stratos ECO T _{min} : +15°C/T _{max} : 110°C				Infinitely variable, 1~230V, 50Hz T _{max} = 95°C or 110°C				1-3-/4-stages 1~230V or 3~400V, 50Hz T _{max} = 110°C or 130°C/140°C			
DN Type	PN	Motor	Overall length [mm]	Type	Motor	Overall length [mm]	Adapter/Remark	Type	Motor	Overall length [mm]	Adapter/Remark	Type	Motor	Overall length [mm]	Adapter/Remark
Rp 1¼ (Pump thread G 2)															
Stratos ECO 30/1-3	10	1	180	Stratos ECO 30/1-3	1	180	-	-	-	-	-	-	-	-	-
Stratos ECO 30/1-5	10	1	180	Stratos ECO 30/1-5	1	180	-	-	-	-	-	-	-	-	-
TOP-D 30	10	1/3	180	-	-	-	-	Star-E 30/1-5	1	180	-	TOP-D 30	1/3	180	-
TOP-E 30/1-10	10	1	180	Stratos 30/1-12	1	180	-	TOP-E 30/1-10	1	180	-	-	-	-	-
TOP-E 30/1-7 (RG)	10	1	180	Stratos 30/1-8	1	180	-	TOP-E 30/1-7 (RG)	1	180	-	-	-	-	-
TOP-S (RS) 30/10	10	1/3	180	Stratos 30/1-12	1	180	-	TOP-E 30/1-10	1	180	-	TOP-S 30/10	1/3	180	-
TOP-S (RS) 30/7	10	1/3	180	Stratos 30/1-8	1	180	-	TOP-E 30/1-7	1	180	-	TOP-S 30/7	1/3	180	-
TOP-S 30/4	10	1/3	180	Stratos 30/1-6	1	180	-	TOP-E 30/1-7	1	180	-	TOP-S 30/4	1/3	180	-
TOP-S 30/5	10	1/3	180	Stratos 30/1-6	1	180	-	TOP-E 30/1-7	1	180	-	TOP-S 30/5	1/3	180	-
DN 32															
Stratos 32/1-12	6/10	1	220	Stratos 32/1-12	1	220	-	-	-	-	-	-	-	-	-
DN 40															
D 40	6/10	1/3	220	-	-	-	-	Star-E 25/1-5	1	180	2 x RF9(PN6)	TOP-D 40	1/3	220	-
P 40-1, P 40-2	6/10	1/3	250	Stratos 40/1-4	1	220	F1	TOP-E 40/1-4	1	220	F1	P 40/100 r	1/3	250	-
P 40/100 v (r)	6/10	1/3	250	Stratos 40/1-4	1	220	F1	TOP-E 40/1-4	1	220	F1	P 40/100 r	1/3	250	-
P 40/140	6/10	3	320	Stratos 40/1-4	1	220	2 x F26	TOP-E 40/1-4	1	220	2 x F26	P 40/160 r	3	320	-
P 40/160 (v) (r)	6/10	3	320	Stratos 40/1-8	1	220	2 x F26	TOP-E 40/1-10	1	250	F0+F26+Di	P 40/160 r	3	320	-
RS 40	6/10	1/3	220	Stratos 40/1-4	1	220	-	TOP-E 40/1-4	1	220	-	TOP-S 40/4	1/3	220	-
S 40/80 v (r)	6/10	1/3	220	Stratos 40/1-4	1	220	-	TOP-E 40/1-4	1	220	-	TOP-S 40/4	1/3	220	-
S 40/90 (v) (r)	6/10	1/3	250	Stratos 40/1-8	1	220	F1	TOP-E 40/1-10	1	250	-	TOP-S 40/7	1/3	250	-
Star-E 40/1-5	6/10	1	220	Stratos 40/1-4	1	220	-	TOP-E 40/1-4	1	220	-	-	-	-	-
Stratos 40/1-12	6/10	1	250	Stratos 40/1-12	1	250	-	-	-	-	-	-	-	-	-
Stratos 40/1-4	6/10	1	220	Stratos 40/1-4	1	220	-	-	-	-	-	-	-	-	-
Stratos 40/1-8	6/10	1	220	Stratos 40/1-8	1	220	-	-	-	-	-	-	-	-	-
TOP-D 40	6/10	1/3	220	-	-	-	-	Star-E 25/1-5	1	180	2 x RF9(PN6)	TOP-D 40	1/3	220	-
TOP-E 40/1-10	6/10	1	250	Stratos 40/1-12	1	250	-	TOP-E 40/1-10	1	250	-	-	-	-	-
TOP-E 40/1-4	6/10	1	220	Stratos 40/1-4	1	220	-	TOP-E 40/1-4	1	220	-	-	-	-	-
TOP-S 40/10	6/10	3	250	Stratos 40/1-12	1	250	-	TOP-E 40/1-10	1	250	-	TOP-S 40/10	3	250	-
TOP-S 40/15	6/10	3	250	-	-	-	-	-	-	-	-	TOP-S 40/15	3	250	-
TOP-S 40/4	6/10	1/3	220	Stratos 40/1-4	1	220	-	TOP-E 40/1-4	1	220	-	TOP-S 40/4	1/3	220	-
TOP-S 40/7	6/10	1/3	250	Stratos 40/1-8	1	220	F1	TOP-E 40/1-10	1	250	-	TOP-S 40/7	1/3	250	-
DN 50															
D 50	6/10	1/3	240	-	-	-	-	-	-	-	-	TOP-D 50	1/3	240	-
P 50-1, P 50-2	6/10	1/3	280	Stratos 50/1-8	1	240	2 x F3	TOP-E 50/1-6	1	240	2 x F3	P 50/125 r	3	280	-
P 50/125 v (r)	6/10	3	280	Stratos 50/1-8	1	240	2 x F3	TOP-E 50/1-6	1	240	2 x F3	P 50/125 r	3	280	-
P 50/140	6/10	3	340	Stratos 50/1-9	1	280	2 x F4	TOP-E 50/1-7	1	280	2 x F4	P 50/160 r	3	340	-
P 50/160 (v) (r)	6/10	3	340	Stratos 50/1-9	1	280	2 x F4	TOP-E 50/1-7	1	280	2 x F4	P 50/160 r	3	340	-
P 50/200, P 50/224	10	3	460	Stratos 50/1-9	1	280	Mod. pipe	TOP-E 50/1-10	1	280	Mod. pipe	P 50/250 r	3	440	F3
P 50/250 (v)	10	3	460	Stratos 50/1-12	1	280	Mod. pipe	IP-E 50/115-0,75/2	3	280	Mod. pipe	P 50/250 r	3	440	F3
P 50/250 r	10	3	440	Stratos 50/1-12	1	280	Mod. pipe	IP-E 50/115-0,75/2	3	280	Mod. pipe	P 50/250 r	3	440	-
RS 50	6/10	1/3	240	Stratos 50/1-8	1	240	-	TOP-E 50/1-6	1	240	-	TOP-S 50/4	1/3	240	-

*) Energy efficiency class for each type see page 3-5

■ = Replacement pumps in accordance with EnEV (German Energy Saving Ordinance)

Observe current type (three-phase/single-phase) and nominal pressure of pump (PN 6/PN 10)! — 1 = 1~230 V single-phase, 3 = 3~400 V three-phase

Check separately whether existing switchgears can be used.

Wilo Replacement Guide Heating

Wilo

Single-head pumps



DN
Type

PN
Motor
Overall length
[mm]

Wilo – new



High-efficiency pumps

Infinitely variable, 1 ~ 230V, 50Hz
Stratos $T_{min}: -10^{\circ}C/T_{max}: 110^{\circ}C$
Stratos ECO $T_{min}: +15^{\circ}C/T_{max}: 110^{\circ}C$

Type

Motor
Overall length
[mm]
Adapter/
Remark



Energy-saving pumps*)

Infinitely variable, 1 ~ 230V,
50Hz
 $T_{max} = 95^{\circ}C$ or $110^{\circ}C$

Type

Motor
Overall length
[mm]
Adapter/
Remark

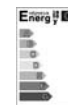

Standard pumps*)

1-/3-/4-stages
1 ~ 230V or 3 ~ 400V, 50Hz
 $T_{max} = 110^{\circ}C$ or $130^{\circ}C/140^{\circ}C$

Type

Motor
Overall length
[mm]
Adapter/
Remark

DN 50

DN 50	PN	Motor	Overall length [mm]	Type	Motor	Overall length [mm]	Adapter/Remark	Type	Motor	Overall length [mm]	Adapter/Remark
S 50/100 (v) (r)	6/10	3	280	Stratos 50/1-9	1	280	-	TOP-E 50/1-7	1	280	-
S 50/125 r	6/10	3	280	Stratos 50/1-12	1	280	-	TOP-E 50/1-10	1	280	-
S 50/140 r	6/10	3	340	-	-	-	-	-	-	-	-
S 50/80 v (r)	6/10	1/3	240	Stratos 50/1-8	1	240	-	TOP-E 50/1-6	1	240	-
Star-E 50/1-7	6/10	1	240	Stratos 50/1-8	1	240	-	TOP-E 50/1-6	1	240	-
Stratos 50/1-12	6/10	1	280	Stratos 50/1-12	1	280	-	-	-	-	-
Stratos 50/1-8	6/10	1	240	Stratos 50/1-8	1	240	-	-	-	-	-
Stratos 50/1-9	6/10	1	280	Stratos 50/1-9	1	280	-	-	-	-	-
TOP-D 50	6/10	1/3	240	-	-	-	-	-	-	-	-
TOP-E 50/1-10	6/10	1	280	Stratos 50/1-12	1	280	-	TOP-E 50/1-10	1	280	-
TOP-E 50/1-6	6/10	1	240	Stratos 50/1-8	1	240	-	TOP-E 50/1-6	1	240	-
TOP-E 50/1-7 (RG)	6/10	1	280	Stratos 50/1-9	1	280	-	TOP-E 50/1-7 (RG)	1	280	-
TOP-S 50/10	6/10	3	280	Stratos 50/1-12	1	280	-	TOP-E 50/1-10	1	280	-
TOP-S 50/15	6/10	3	340	-	-	-	-	-	-	-	-
TOP-S 50/4	6/10	1/3	240	Stratos 50/1-8	1	240	-	TOP-E 50/1-6	1	240	-
TOP-S 50/7	6/10	3	280	Stratos 50/1-9	1	280	-	TOP-E 50/1-7	1	280	-

DN 65

DN 65	PN	Motor	Overall length [mm]	Type	Motor	Overall length [mm]	Adapter/Remark	Type	Motor	Overall length [mm]	Adapter/Remark
D 65	6/10	1/3	280	-	-	-	-	-	-	-	-
P 65-1, P 65-2	6/10	1/3	340	Stratos 65/1-9	1	280	2xF11	TOP-E 65/1-10	1	340	-
P 65/125 v (r)	6/10	3	340	Stratos 65/1-9	1	280	2xF11	TOP-E 65/1-10	1	340	-
P 65/140	6/10	3	340	Stratos 65/1-9	1	280	2xF11	TOP-E 65/1-10	1	340	-
P 65/160 (v) (r)	6/10	3	340	Stratos 65/1-9	1	280	2xF11	TOP-E 65/1-10	1	340	-
P 65/200, P 65/224	10	3	500	Stratos 65/1-12	1	340	Mod. pipe	IP-E 65/115-1,5/2	3	340	Mod. pipe
P 65/250 (v)	10	3	500	-	-	-	-	IP-E 65/115-1,5/2	3	340	Mod. pipe
P 65/250 r	10	3	475	-	-	-	-	IP-E 65/115-1,5/2	3	340	Mod. pipe
RS 65	6/10	1/3	280	Stratos 65/1-9	1	280	-	TOP-E 65/1-10	1	340	Mod. pipe
S 65/110	6/10	3	340	Stratos 65/1-9	1	280	2xF11	TOP-E 65/1-10	1	340	-
S 65/125 (v) (r)	6/10	3	340	Stratos 65/1-12	1	340	-	-	-	-	-
S 65/140 r	6/10	3	340	-	-	-	-	IP-E 65/115-1,5/2	3	340	-
S 65/80 v (r)	6/10	3	280	Stratos 65/1-9	1	280	-	TOP-E 65/1-10	1	340	Mod. pipe
Stratos 65/1-12	6/10	1	340	Stratos 65/1-12	1	340	-	-	-	-	-
Stratos 65/1-9	6/10	1	280	Stratos 65/1-9	1	280	-	-	-	-	-
TOP-D 65	6/10	1/3	280	-	-	-	-	-	-	-	-
TOP-E 65/1-10 (RG)	6/10	1	340	Stratos 65/1-12	1	340	-	TOP-E 65/1-10 (RG)	1	340	-
TOP-S 65/10	6/10	3	340	Stratos 65/1-12	1	340	-	TOP-E 65/1-10	1	340	-
TOP-S 65/13	6/10	3	340	-	-	-	-	IP-E 65/115-1,5/2	3	340	-
TOP-S 65/15	6/10	3	340	-	-	-	-	IP-E 65/115-1,5/2	3	340	-
TOP-S 65/7	6/10	3	280	Stratos 65/1-9	1	280	-	TOP-E 65/1-10	1	340	Mod. pipe

*) Energy efficiency class for each type see page 3-5

■ = Replacement pumps in accordance with EnEV (German Energy Saving Ordinance)

Observe current type (three-phase/single-phase) and nominal pressure of pump (PN 6/PN 10)! — 1 = 1 ~ 230 V single-phase, 3 = 3 ~ 400 V three-phase

Check separately whether existing switchgears can be used.

Wilo				Wilo – new											
Single-head pumps				High-efficiency pumps				Energy-saving pumps ^{*)}				Standard pumps ^{*)}			
				Infinitely variable, 1~230V, 50Hz Stratos T _{min} : -10°C/T _{max} : 110°C Stratos ECO T _{min} : +15°C/T _{max} : 110°C				Infinitely variable, 1~230V, 50Hz T _{max} = 95°C or 110°C				1-3-/4-stages 1~230V or 3~400V, 50Hz T _{max} = 110°C or 130°C/140°C			
DN Type	PN	Motor	Overall length [mm]	Type	Motor	Overall length [mm]	Adapter/Remark	Type	Motor	Overall length [mm]	Adapter/Remark	Type	Motor	Overall length [mm]	Adapter/Remark
DN 80															
D 80	6/10	1/3	330	–	–	–	–	–	–	–	–	TOP-D 80	1/3	330	–
P 80-1, P 80-2	6/10	3	360	Stratos 80/1-12	1	360	–	TOP-E 80/1-10	1	360	–	P 80/125 r	3	360	–
P 80/125 v (r)	6/10	3	360	Stratos 80/1-12	1	360	–	TOP-E 80/1-10	1	360	–	P 80/125 r	3	360	–
P 80/160 (v) (r)	6/10	3	360	Stratos 80/1-12	1	360	–	TOP-E 80/1-10	1	360	–	P 80/160 r	3	360	–
P 80/200, P 80/224	10	3	500	Stratos 80/1-12	1	360	Mod.pipe	TOP-E 80/1-10	1	360	Mod.pipe	P 80/250 r	3	500	–
P 80/250 (v) (r)	10	3	500	Stratos 80/1-12	1	360	Mod.pipe	IP-E 80/115-2,2/2	3	360	Mod.pipe	P 80/250 r	3	500	–
S 80	6/10	3	360	Stratos 80/1-12	1	360	–	TOP-E 80/1-10	1	360	–	TOP-S 80/10	3	360	–
S 80/100 v	6/10	3	360	Stratos 80/1-12	1	360	–	TOP-E 80/1-10	1	360	–	TOP-S 80/10	3	360	–
S 80/110	6/10	3	360	Stratos 80/1-12	1	360	–	TOP-E 80/1-10	1	360	–	TOP-S 80/10	3	360	–
S 80/125 (v) (r)	6/10	3	360	Stratos 80/1-12	1	360	–	TOP-E 80/1-10	1	360	–	TOP-S 80/10	3	360	–
Stratos 80/1-12	6/10	1	360	Stratos 80/1-12	1	360	–	–	–	–	–	–	–	–	–
TOP-D 80	6/10	1/3	330	–	–	–	–	–	–	–	–	TOP-D 80	1/3	330	–
TOP-E 80/1-10 (RG)	6/10	1	360	Stratos 80/1-12	1	360	–	TOP-E 80/1-10 (RG)	1	360	–	–	–	–	–
TOP-S 80/10	6/10	3	360	Stratos 80/1-12	1	360	–	TOP-E 80/1-10	1	360	–	TOP-S 80/10	3	360	–
TOP-S 80/7	6/10	3	360	Stratos 80/1-12	1	360	–	TOP-E 80/1-10	1	360	–	TOP-S 80/7	3	360	–
DN 100															
D 100	6/10	1/3	380	–	–	–	–	–	–	–	–	TOP-D 100	1/3	380	–
P 100-1, P 100-2	6/10	3	395	Stratos 100/1-12	1	360	F34(PN6)	TOP-E 100/1-10	1	360	F34(PN6)	P 100/160 r	3	395	–
P 100/160 v (r)	6/10	3	395	Stratos 100/1-12	1	360	F34(PN6)	TOP-E 100/1-10	1	360	F34(PN6)	P 100/160 r	3	395	–
P 100/180	6/10	3	500	–	–	–	–	IP-E 80/115-2,2/2	3	360	Mod.pipe	P 100/200 r	3	550	Mod.pipe
P 100/200 (v)	10	3	500	–	–	–	–	IP-E 80/115-2,2/2	3	360	Mod.pipe	P 100/200 r	3	550	Mod.pipe
P 100/200 r	10	3	550	–	–	–	–	IP-E 80/115-2,2/2	3	360	Mod.pipe	P 100/200 r	3	550	–
S 100/125 v (r)	6/10	3	395	Stratos 100/1-12	1	360	F34(PN6)	TOP-E 100/1-10	1	360	F34(PN6)	TOP-S 100/10	3	360	F34(PN6)
Stratos 100/1-12	6/10	1	360	Stratos 100/1-12	1	360	–	–	–	–	–	–	–	–	–
TOP-D 100	6/10	1/3	380	–	–	–	–	–	–	–	–	TOP-D 100	1/3	380	–
TOP-E 100/1-10	6/10	1	360	Stratos 100/1-12	1	360	–	TOP-E 100/1-10	1	360	–	–	–	–	–
TOP-S 100/10	6/10	3	360	Stratos 100/1-12	1	360	–	TOP-E 100/1-10	1	360	–	TOP-S 100/10	3	360	–
DN 125															
D 125	6/10	3	450	–	–	–	–	–	–	–	–	TOP-D 125	3	450	–

^{*)} Energy efficiency class for each type see page 3–5

■ = Replacement pumps in accordance with EnEV (German Energy Saving Ordinance)

Observe current type (three-phase/single-phase) and nominal pressure of pump (PN 6/PN 10)! — 1 = 1~230 V single-phase, 3 = 3~400 V three-phase

Check separately whether existing switchgears can be used.

Wilo Replacement Guide Heating

Wilo

Twin-head pumps



DN
Type

PN
Motor
Overall length
[mm]

Wilo – new



High-efficiency pumps

Infinitely variable, 1 ~ 230V, 50Hz
Stratos $T_{min}: -10^{\circ}C/T_{max}: 110^{\circ}C$
Stratos ECO $T_{min}: +15^{\circ}C/T_{max}: 110^{\circ}C$

Type

Motor
Overall length
[mm]
Adapter/
Remark



Energy-saving pumps*)

Infinitely variable, 1 ~ 230V,
50Hz
 $T_{max} = 95^{\circ}C$ or $110^{\circ}C$

Type

Motor
Overall length
[mm]
Adapter/
Remark



Standard pumps*)

1-/3-/4-stages
1 ~ 230V or 3 ~ 400V, 50Hz
 $T_{max} = 110^{\circ}C$ or $130^{\circ}C/140^{\circ}C$

Type

Motor
Overall length
[mm]
Adapter/
Remark

Rp 1 1/4 (Pump thread G 2)

Wilo	PN	Motor	Overall length [mm]	High-efficiency pumps	Energy-saving pumps*)	Standard pumps*)
DORS 30/60 r	10	1	180	-	-	Star-RSD 30/4 1 180 -
DORS 30/70 r	10	1	180	-	-	Star-RSD 30/6 1 180 -
Star-RSD 30/4	10	1	180	-	-	Star-RSD 30/4 1 180 -
Star-RSD 30/6	10	1	180	-	-	Star-RSD 30/6 1 180 -
TOP-SD 30/5	10	1/3	180	-	-	TOP-SD 30/5 1/3 180 -

DN 32

Wilo	PN	Motor	Overall length [mm]	High-efficiency pumps	Energy-saving pumps*)	Standard pumps*)
DOP 32/80 v (r)	6/10	1/3	220	Stratos-D 32/1-8 1 220 -	TOP-ED 32/1-7 1 220 -	- - -
DOS 32/80 v (r)	6/10	1/3	220	Stratos-D 32/1-8 1 220 -	TOP-ED 32/1-7 1 220 -	TOP-SD 32/7 1/3 220 -
Stratos-D 32/1-12	6/10	1	220	Stratos-D 32/1-12 1 220 -	-	- - -
Stratos-D 32/1-8	6/10	1	220	Stratos-D 32/1-8 1 220 -	-	- - -
TOP-ED 32/1-7	6/10	1	220	Stratos-D 32/1-8 1 220 -	TOP-ED 32/1-7 1 220 -	- - -
TOP-SD 32/7	6/10	1/3	220	Stratos-D 32/1-8 1 220 -	TOP-ED 32/1-7 1 220 -	TOP-SD 32/7 1/3 220 -
TS 30/60	6/10	1/3	400	-	-	Star-RSD 30/4 1 180 Mod. pipe
TS 30/70	6/10	1/3	400	-	-	Star-RSD 30/6 1 180 Mod. pipe

DN 40

Wilo	PN	Motor	Overall length [mm]	High-efficiency pumps	Energy-saving pumps*)	Standard pumps*)
DOP 40/100 v (r)	6/10	1/3	250	Stratos-D 40/1-8 1 220 F1	TOP-ED 40/1-7 1 250 -	DOP 40/100 r 1/3 250 -
DOP 40/160 r	6/10	3	320	Stratos-D 40/1-8 1 220 2xF26	TOP-ED 40/1-7 1 250 F0+F26+Di	DOP 40/160 r 3 320 -
DOS 40/90 v (r)	6/10	1/3	250	Stratos-D 40/1-8 1 220 F1	TOP-ED 40/1-7 1 250 -	TOP-SD 40/7 1/3 250 -
Stratos-D 40/1-12	6/10	1	250	Stratos-D 40/1-12 1 250 -	-	- - -
Stratos-D 40/1-8	6/10	1	220	Stratos-D 40/1-8 1 220 -	-	- - -
TOP-ED 40/1-10	6/10	1	250	Stratos-D 40/1-12 1 250 -	TOP-ED 40/1-10 1 250 -	- - -
TOP-ED 40/1-7	6/10	1	250	Stratos-D 40/1-8 1 220 F1	TOP-ED 40/1-7 1 250 -	- - -
TOP-SD 40/10	6/10	3	250	Stratos-D 40/1-12 1 250 -	TOP-ED 40/1-10 1 250 -	TOP-SD 40/10 3 250 -
TOP-SD 40/3	6/10	1/3	250	Stratos-D 40/1-8 1 220 F1	TOP-ED 40/1-7 1 250 -	TOP-SD 40/3 1/3 250 -
TOP-SD 40/7	6/10	1/3	250	Stratos-D 40/1-8 1 220 F1	TOP-ED 40/1-7 1 250 -	TOP-SD 40/7 1/3 250 -
TP 40-1	6/10	1/3	500	Stratos-D 40/1-8 1 220 Mod. pipe	TOP-ED 40/1-7 1 250 Mod. pipe	DOP 40/100 r 1/3 250 Mod. pipe
TP 40-2	6/10	1/3	500	Stratos-D 40/1-8 1 220 Mod. pipe	TOP-ED 40/1-7 1 250 Mod. pipe	DOP 40/100 r 1/3 250 Mod. pipe
TS 40/80	6/10	1/3	500	Stratos-D 40/1-8 1 220 Mod. pipe	TOP-ED 40/1-7 1 250 Mod. pipe	TOP-SD 40/7 1/3 250 Mod. pipe

DN 50

Wilo	PN	Motor	Overall length [mm]	High-efficiency pumps	Energy-saving pumps*)	Standard pumps*)
DOP 50/100 v (r)	6/10	3	280	Stratos-D 50/1-8 1 240 2xF3	TOP-ED 50/1-6 1 280 -	DOP 50/100 r 3 280 -
DOP 50/160 r	6/10	3	340	Stratos-D 50/1-9 1 280 2xF4	TOP-ED 50/1-7 1 280 2xF4	DOP 50/160 r 3 340 -
DOS 50/100 v (r)	6/10	3	280	Stratos-D 50/1-9 1 280 -	TOP-ED 50/1-7 1 280 -	TOP-SD 50/7 3 280 -
DOS 50/125 (r)	6/10	3	280	Stratos-D 50/1-12 1 280 -	TOP-ED 50/1-10 1 280 -	TOP-SD 50/10 3 280 -
DOS 50/140 (r)	6/10	3	340	-	-	TOP-SD 50/15 3 340 -
Stratos-D 50/1-12	6/10	1	280	Stratos-D 50/1-12 1 280 -	-	- - -
Stratos-D 50/1-8	6/10	1	240	Stratos-D 50/1-8 1 240 -	-	- - -
Stratos-D 50/1-9	6/10	1	280	Stratos-D 50/1-9 1 280 -	-	- - -
TOP-ED 50/1-10	6/10	1	280	-	TOP-ED 50/1-10 1 280 -	- - -
TOP-ED 50/1-6	6/10	1	280	Stratos-D 50/1-8 1 240 2xF3	TOP-ED 50/1-6 1 280 -	- - -
TOP-ED 50/1-7	6/10	1	280	Stratos-D 50/1-9 1 280 -	TOP-ED 50/1-7 1 280 -	- - -

*) Energy efficiency class for each type see page 3-5

■ = Replacement pumps in accordance with EnEV (German Energy Saving Ordinance)

Observe current type (three-phase/single-phase) and nominal pressure of pump (PN 6/PN 10)! — 1 = 1 ~ 230 V single-phase, 3 = 3 ~ 400 V three-phase

Check separately whether existing switchgears can be used.

Wilo			Wilo – new								
Twin-head pumps 			High-efficiency pumps Infinitely variable, 1~230V, 50Hz Stratos $T_{min}: -10^{\circ}C/T_{max}: 110^{\circ}C$ Stratos ECO $T_{min}: +15^{\circ}C/T_{max}: 110^{\circ}C$			Energy-saving pumps*) Infinitely variable, 1~230V, 50Hz $T_{max} = 95^{\circ}C$ or $110^{\circ}C$			Standard pumps*) 1-/3-/4-stages 1~230V or 3~400V, 50Hz $T_{max} = 110^{\circ}C$ or $130^{\circ}C/140^{\circ}C$		
DN Type	PN	Motor Overall length [mm]	Type	Motor Overall length [mm]	Adapter/Remark	Type	Motor Overall length [mm]	Adapter/Remark	Type	Motor Overall length [mm]	Adapter/Remark
DN 50											
TOP-SD 50/10	6/10	3 280	Stratos-D 50/1-12	1 280	-	TOP-ED 50/1-10	1 280	-	TOP-SD 50/10	3 280	-
TOP-SD 50/15	6/10	3 340	-	-	-	-	-	-	TOP-SD 50/15	3 340	-
TOP-SD 50/7	6/10	3 280	Stratos-D 50/1-9	1 280	-	TOP-ED 50/1-7	1 280	-	TOP-SD 50/7	3 280	-
TP 50-1	6/10	1/3 560	Stratos-D 50/1-8	1 240	Mod. pipe	TOP-ED 50/1-7	1 280	Mod. pipe	DOP 50/100 r	3 280	Mod. pipe
TP 50-2	6/10	1/3 560	Stratos-D 50/1-8	1 240	Mod. pipe	TOP-ED 50/1-7	1 280	Mod. pipe	DOP 50/100 r	3 280	Mod. pipe
TS 50/100	6/10	3 560	Stratos-D 50/1-9	1 280	Mod. pipe	TOP-ED 50/1-7	1 280	Mod. pipe	TOP-SD 50/7	3 280	Mod. pipe
TS 50/90	6/10	3 560	Stratos-D 50/1-9	1 280	Mod. pipe	TOP-ED 50/1-7	1 280	Mod. pipe	TOP-SD 50/7	3 280	Mod. pipe
DN 65											
DOP 65/125 v (r)	6/10	3 340	Stratos-D 65/1-12	1 340	-	TOP-ED 65/1-10	1 340	-	DOP 65/125 r	3 340	-
DOP 65/160 r	6/10	3 340	Stratos-D 65/1-12	1 340	-	TOP-ED 65/1-10	1 340	-	TOP-SD 65/10	3 340	-
DOS 65/125 v (r)	6/10	3 340	Stratos-D 65/1-12	1 340	-	TOP-ED 65/1-10	1 340	-	TOP-SD 65/10	3 340	-
DOS 65/140 r	6/10	3 340	-	-	-	DP-E 65/115-1,5/2	3 340	-	TOP-SD 65/15	3 340	-
Stratos-D 65/1-12	6/10	1 340	Stratos-D 65/1-12	1 340	-	-	-	-	-	-	-
TOP-ED 65/1-10	6/10	1 340	Stratos-D 65/1-12	1 340	-	TOP-ED 65/1-10	1 340	-	-	-	-
TOP-SD 65/10	6/10	3 340	Stratos-D 65/1-12	1 340	-	TOP-ED 65/1-10	1 340	-	TOP-SD 65/10	3 340	-
TOP-SD 65/13	6/10	3 340	Stratos-D 65/1-12	1 340	-	TOP-ED 80/1-10	1 360	Mod. pipe	TOP-SD 65/13	3 340	-
TOP-SD 65/15	6/10	3 340	Stratos-D 80/1-12	1 360	Mod. pipe	TOP-ED 80/1-10	1 360	Mod. pipe	TOP-SD 65/15	3 340	-
TP 65-1	6/10	1/3 680	Stratos-D 65/1-12	1 340	Mod. pipe	TOP-ED 65/1-10	1 340	Mod. pipe	DOP 65/125 r	3 340	Mod. pipe
TP 65-2	6/10	1/3 680	Stratos-D 65/1-12	1 340	Mod. pipe	TOP-ED 65/1-10	1 340	Mod. pipe	DOP 65/125 r	3 340	Mod. pipe
TS 65/110	6/10	3 680	Stratos-D 65/1-12	1 340	Mod. pipe	TOP-ED 65/1-10	1 340	Mod. pipe	TOP-SD 65/10	3 340	Mod. pipe
TS 65/125	6/10	3 680	Stratos-D 65/1-12	1 340	Mod. pipe	TOP-ED 65/1-10	1 340	Mod. pipe	TOP-SD 65/13	3 340	Mod. pipe
DN 80											
DOP 80/125 v (r)	6/10	3 360	Stratos-D 80/1-12	1 360	-	TOP-ED 80/1-10	1 360	-	DOP 80/125 r	3 360	-
DOP 80/160 r	6/10	3 360	Stratos-D 80/1-12	1 360	-	TOP-ED 80/1-10	1 360	-	TOP-SD 80/10	3 360	-
DOS 80/125 v (r)	6/10	3 360	Stratos-D 80/1-12	1 360	-	TOP-ED 80/1-10	1 360	-	TOP-SD 80/10	3 360	-
Stratos-D 80/1-12	6/10	1 360	Stratos-D 80/1-12	1 360	-	-	-	-	-	-	-
TOP-ED 80/1-10	6/10	1 360	Stratos-D 80/1-12	1 360	-	TOP-ED 80/1-10	1 360	-	-	-	-
TOP-SD 80/10	6/10	3 360	Stratos-D 80/1-12	1 360	-	TOP-ED 80/1-10	1 360	-	TOP-SD 80/10	3 360	-
TP 80-1	6/10	1/3 720	Stratos-D 80/1-12	1 360	Mod. pipe	TOP-ED 80/1-10	1 360	Mod. pipe	DOP 80/125 r	3 360	Mod. pipe
TS 80/125	6/10	3 720	Stratos-D 80/1-12	1 360	Mod. pipe	TOP-ED 80/1-10	1 360	Mod. pipe	TOP-SD 80/10	3 360	Mod. pipe
DN 100											
DOP 100/160 r	6/10	3 395	Stratos-D 80/1-12	1 360	Mod. pipe	TOP-ED 80/1-10	1 360	Mod. pipe	DOP 100/160 r	3 395	-
DOS 100/125 r	6/10	3 395	Stratos-D 80/1-12	1 360	Mod. pipe	TOP-ED 80/1-10	1 360	Mod. pipe	TOP-SD 80/10	3 360	Mod. pipe

*) Energy efficiency class for each type see page 3-5

= Replacement pumps in accordance with EnEV (German Energy Saving Ordinance)

Observe current type (three-phase/single-phase) and nominal pressure of pump (PN 6/PN 10)! — 1 = 1~230 V single-phase, 3 = 3~400 V three-phase

Check separately whether existing switchgears can be used.

Wilo Replacement Guide Heating

Grundfos

Single-head pumps



DN
Type

PN
Motor
Overall length
[mm]

Wilo – new



High-efficiency pumps

Infinitely variable, 1 ~ 230V, 50Hz
Stratos $T_{min}: -10^{\circ}C/T_{max}: 110^{\circ}C$
Stratos ECO $T_{min}: +15^{\circ}C/T_{max}: 110^{\circ}C$



Energy-saving pumps*)

Infinitely variable, 1 ~ 230V,
50Hz
 $T_{max} = 95^{\circ}C$ or $110^{\circ}C$



Standard pumps*)

1-/3-/4-stages
1 ~ 230V or 3 ~ 400V, 50Hz
 $T_{max} = 110^{\circ}C$ or $130^{\circ}C/140^{\circ}C$

Type
Motor
Overall length
[mm]
Adapter/
Remark

Type
Motor
Overall length
[mm]
Adapter/
Remark

Type
Motor
Overall length
[mm]
Adapter/
Remark

Rp 1/2 (Pump thread G 1)

Grundfos Model	PN	Motor	Overall length [mm]	Wilo Model	Motor	Overall length [mm]	Adapter/Remark	Wilo Model	Motor	Overall length [mm]	Adapter/Remark	Wilo Model	Motor	Overall length [mm]	Adapter/Remark
Alpha 15-40 130	10	1	130	Stratos ECO 25/1-3	1	180	Mod. pipe	Star-E 15/1-3-130	1	130	-	-	-	-	-
Alpha 15-60 130	10	1	130	Stratos ECO 25/1-5	1	180	Mod. pipe	Star-E 15/1-5-130	1	130	-	-	-	-	-
UPE 15-40 130	10	1	130	-	-	-	-	Star-E 15/1-3-130	1	130	-	-	-	-	-
UPE 15-60 130	10	1	130	-	-	-	-	Star-E 15/1-5-130	1	130	-	-	-	-	-
UPS 15-20 130	10	1	130	-	-	-	-	Star-E 15/1-3-130	1	130	-	Star-RS 15/2-130	1	130	-
UPS 15-30 130	10	1	130	-	-	-	-	Star-E 15/1-3-130	1	130	-	Star-RS 15/2-130	1	130	-
UPS 15-40 130	10	1	130	-	-	-	-	Star-E 15/1-5-130	1	130	-	Star-RS 15/4-130	1	130	-
UPS 15-45x16	10	1	130	-	-	-	-	Star-E 15/1-5-130	1	130	-	Star-RS 15/4-130	1	130	-
UPS 15-50 130	10	1	130	-	-	-	-	Star-E 15/1-5-130	1	130	-	Star-RS 15/6-130	1	130	-
UPS 15-60 130	10	1	130	-	-	-	-	Star-E 15/1-5-130	1	130	-	Star-RS 15/6-130	1	130	-

Rp 3/4 (Pump thread G 1 1/4)

Grundfos Model	PN	Motor	Overall length [mm]	Wilo Model	Motor	Overall length [mm]	Adapter/Remark	Wilo Model	Motor	Overall length [mm]	Adapter/Remark	Wilo Model	Motor	Overall length [mm]	Adapter/Remark
UM 17-20	10	1	130	Stratos ECO 25/1-5-130	1	130	Mod. pipe	Star-E 15/1-3-130	1	130	Mod. pipe	Star-RS 15/4-130	1	130	Mod. pipe
UM 17-20	10	3	130	-	-	-	-	-	-	-	-	RP 25/80 r	1/3	180	Mod. pipe
UMS 17-20	10	1	130	Stratos ECO 25/1-5-130	1	130	Mod. pipe	Star-E 15/1-3-130	1	130	Mod. pipe	Star-RS 15/4-130	1	130	Mod. pipe
UP 15-12 x 17	10	1	130	Stratos ECO 25/1-5-130	1	130	Mod. pipe	Star-E 15/1-3-130	1	130	Mod. pipe	Star-RS 15/4-130	1	130	Mod. pipe
UP 17-35	10	1	130	Stratos ECO 25/1-5-130	1	130	Mod. pipe	Star-E 25/1-5-130	1	130	Mod. pipe	Star-RS 25/4-130	1	130	Mod. pipe
UP 17-35	10	3	130	Stratos ECO 25/1-5-130	1	130	Mod. pipe	-	-	-	-	RP 25/80 r	1/3	180	Mod. pipe
UP 17-50	10	1	130	-	-	-	-	Star-E 15/1-5-130	1	130	Mod. pipe	Star-RS 25/4-130	1	130	Mod. pipe
UP 17-50	10	3	130	-	-	-	-	-	-	-	-	RP 25/100 r	1/3	180	Mod. pipe
UPS 15-20x17	10	1	130	Stratos ECO 25/1-5-130	1	130	Mod. pipe	Star-E 15/1-3-130	1	130	Mod. pipe	Star-RS 15/4-130	1	130	Mod. pipe
UPS 15-35x17	10	1	130	Stratos ECO 25/1-5-130	1	130	Mod. pipe	Star-E 25/1-3-130	1	130	Mod. pipe	Star-RS 25/4-130	1	130	Mod. pipe
UPS 15-45x17	10	1	130	Stratos ECO 25/1-5-130	1	130	Mod. pipe	Star-E 25/1-5-130	1	130	Mod. pipe	Star-RS 25/4-130	1	130	Mod. pipe
UPS 17-35	10	1	130	Stratos ECO 25/1-5-130	1	130	Mod. pipe	Star-E 25/1-3-130	1	130	Mod. pipe	Star-RS 25/4-130	1	130	Mod. pipe
UPS 17-45	10	1	130	Stratos ECO 25/1-5-130	1	130	Mod. pipe	Star-E 25/1-5-130	1	130	Mod. pipe	Star-RS 25/4-130	1	130	Mod. pipe
UPS 17-60	10	1	130	Stratos ECO 25/1-5-130	1	130	Mod. pipe	Star-E 25/1-5-130	1	130	Mod. pipe	Star-RS 25/6-130	1	130	Mod. pipe
UPS 20-20 XD	10	1	180	Stratos ECO 25/1-3	1	180	Mod. pipe	Star-E 25/1-3	1	180	Mod. pipe	Star-RS 25/2	1	180	Mod. pipe
UPS 20-40 130	10	1	130	Stratos ECO 25/1-5-130	1	130	Mod. pipe	Star-E 25/1-3-130	1	130	Mod. pipe	Star-RS 25/4-130	1	130	Mod. pipe
UPS 20-40 XD	10	1	180	Stratos ECO 25/1-5	1	180	Mod. pipe	Star-E 25/1-3	1	180	Mod. pipe	Star-RS 25/4	1	180	Mod. pipe
UPS 20-50 130	10	1	130	Stratos ECO 25/1-5-130	1	130	Mod. pipe	Star-E 25/1-5-130	1	130	Mod. pipe	Star-RS 25/6-130	1	130	Mod. pipe
UPS 20-60 130	10	1	130	Stratos ECO 25/1-5-130	1	130	Mod. pipe	Star-E 25/1-5-130	1	130	Mod. pipe	Star-RS 25/6-130	1	130	Mod. pipe

Rp 1 (Pump thread G 1 1/2)

Grundfos Model	PN	Motor	Overall length [mm]	Wilo Model	Motor	Overall length [mm]	Adapter/Remark	Wilo Model	Motor	Overall length [mm]	Adapter/Remark	Wilo Model	Motor	Overall length [mm]	Adapter/Remark
Alpha 25-40	10	1	180	Stratos ECO 25/1-3	1	180	-	Star-E 25/1-3	1	180	-	-	-	-	-
Alpha 25-40 130	10	1	130	Stratos ECO 25/1-5-130	1	130	-	Star-E 25/1-3-130	1	130	-	-	-	-	-
Alpha 25-60	10	1	180	Stratos ECO 25/1-5	1	180	-	Star-E 25/1-5	1	180	-	-	-	-	-
Alpha 25-60 130	10	1	130	Stratos ECO 25/1-5-130	1	130	-	Star-E 25/1-3-130	1	130	-	-	-	-	-
Alpha Pro 25-40	10	1	180	Stratos ECO 25/1-3	1	180	-	-	-	-	-	-	-	-	-
Alpha Pro 25-40 130	10	1	130	Stratos ECO 25/1-5-130	1	130	-	-	-	-	-	-	-	-	-
Alpha Pro 25-60	10	1	180	Stratos ECO 25/1-5	1	180	-	-	-	-	-	-	-	-	-
Alpha Pro 25-60 130	10	1	130	Stratos ECO 25/1-5-130	1	130	-	-	-	-	-	-	-	-	-
Alpha+ 25-40	10	1	180	Stratos ECO 25/1-3	1	180	-	Star-E 25/1-3	1	180	-	-	-	-	-
Alpha+ 25-40 130	10	1	130	Stratos ECO 25/1-5-130	1	130	-	Star-E 25/1-3-130	1	130	-	-	-	-	-

*) Energy efficiency class for each type see page 3-5

■ = Replacement pumps in accordance with EnEV (German Energy Saving Ordinance)

Observe current type (three-phase/single-phase) and nominal pressure of pump (PN 6/PN 10)! — 1 = 1 ~ 230 V single-phase, 3 = 3 ~ 400 V three-phase

Check separately whether existing switchgears can be used.

Grundfos				Wilo – new							
Single-head pumps				High-efficiency pumps Infinitely variable, 1~ 230V, 50Hz Stratos T _{min} : -10°C/T _{max} : 110°C Stratos ECO T _{min} : +15°C/T _{max} : 110°C		Energy-saving pumps*) Infinitely variable, 1~ 230V, 50Hz T _{max} = 95°C or 110°C		Standard pumps*) 1-3-/4-stages 1~ 230V or 3~ 400V, 50Hz T _{max} = 110°C or 130°C/140°C			
DN Type	PN	Motor	Overall length [mm]	Type	Motor	Overall length [mm]	Adapter/Remark	Type	Motor	Overall length [mm]	Adapter/Remark

Rp 1 (Pump thread G 1½)

Alpha+ 25-60	10	1	180	Stratos ECO 25/1-5	1	180	-	Star-E 25/1-5	1	180	-
Alpha+ 25-60 130	10	1	130	Stratos ECO 25/1-5-130	1	130	-	Star-E 25/1-5-130	1	130	-

Rp 1 (Pump thread G 1½)

Magna 25-100	10	1	180	Stratos 25/1-8	1	180	-	-	-	-	-
Magna 25-60	10	1	180	Stratos 25/1-6	1	180	-	-	-	-	-
UM 18-20	10	3	130	-	-	-	-	Star-E 25/1-3-130	1	130	-
UM 19-20	10	1	160	Stratos ECO 25/1-5-130	1	130	R1	Star-E 25/1-3-130	1	130	R1
UM 19-20	10	3	160	-	-	-	-	-	-	-	-
UM 20-20	10	1/3	180	Stratos ECO 25/1-3	1	180	-	Star-E 25/1-3	1	180	-
UM 25-20 (Th)	10	3	180	Stratos ECO 25/1-5	1	180	-	Star-E 25/1-5	1	180	-
UMS 18-20	10	1	130	Stratos ECO 25/1-5-130	1	130	-	Star-E 25/1-3-130	1	130	-
UMS 19-20	10	1	160	Stratos ECO 25/1-5-130	1	130	R1	Star-E 25/1-3-130	1	130	R1
UMS 20-20	10	1	180	Stratos ECO 25/1-3	1	180	-	Star-E 25/1-3	1	180	-
UMS 25-20	10	1	180	Stratos ECO 25/1-3	1	180	-	Star-E 25/1-3	1	180	-
UP 18-35	10	1	130	Stratos ECO 25/1-5-130	1	130	-	Star-E 25/1-3-130	1	130	-
UP 18-35	10	3	130	-	-	-	-	-	-	-	-
UP 18-50	10	1	130	Stratos ECO 25/1-5-130	1	130	-	Star-E 25/1-5-130	1	130	-
UP 18-50	10	3	130	-	-	-	-	-	-	-	-
UP 18-65	10	1	130	Stratos ECO 25/1-5-130	1	130	-	Star-E 25/1-5-130	1	130	-
UP 19-35	10	1	160	Stratos ECO 25/1-5-130	1	130	R1	Star-E 25/1-3-130	1	130	R1
UP 19-35	10	3	160	-	-	-	-	-	-	-	-
UP 19-50	10	1	160	Stratos ECO 25/1-5-130	1	130	R1	Star-E 25/1-3-130	1	130	R1
UP 19-50	10	3	160	-	-	-	-	-	-	-	-
UP 20-20	10	1/3	180	Stratos ECO 25/1-3	1	180	-	Star-E 25/1-3	1	180	-
UP 20-35	10	1	180	Stratos ECO 25/1-5	1	180	-	Star-E 25/1-5	1	180	-
UP 20-35	10	3	180	-	-	-	-	-	-	-	-
UP 20-50	10	1	180	Stratos ECO 25/1-5	1	180	-	Star-E 25/1-5	1	180	-
UP 20-50	10	3	180	-	-	-	-	-	-	-	-
UP 25-25	10	3	180	-	-	-	-	-	-	-	-
UP 25-55 Th	10	3	180	-	-	-	-	-	-	-	-
UP 25-80 (Th)	10	3	180	Stratos 25/1-8	1	180	-	TOP-E 25/1-7	1	180	-
UP 26-65	10	1/3	180	Stratos ECO 25/1-5	1	180	-	Star-E 25/1-5	1	180	-
UP 26-80	10	3	180	Stratos 25/1-8	1	180	-	TOP-E 25/1-7	1	180	-
UPE 25-25	10	1	180	Stratos ECO 25/1-3	1	180	-	Star-E 25/1-3	1	180	-
UPE 25-40	10	1	180	Stratos ECO 25/1-3	1	180	-	Star-E 25/1-3	1	180	-
UPE 25-40 130	10	1	130	Stratos ECO 25/1-5-130	1	130	-	Star-E 25/1-3-130	1	130	-
UPE 25-45	10	1	180	Stratos ECO 25/1-5	1	180	-	Star-E 25/1-5	1	180	-
UPE 25-60	10	1	180	Stratos ECO 25/1-5	1	180	-	Star-E 25/1-5	1	180	-
UPE 25-60 130	10	1	130	Stratos ECO 25/1-5-130	1	130	-	Star-E 25/1-5-130	1	130	-
UPE 25-80	10	1	180	Stratos 25/1-8	1	180	-	TOP-E 25/1-10	1	180	-
UPI 15-35x20	10	1	180	Stratos ECO 25/1-3	1	180	-	Star-E 25/1-3	1	180	-
UPI 15-45 x20	10	1	180	Stratos ECO 25/1-5	1	180	-	Star-E 25/1-5	1	180	-

*) Energy efficiency class for each type see page 3-5

■ = Replacement pumps in accordance with EnEV (German Energy Saving Ordinance)

Observe current type (three-phase/single-phase) and nominal pressure of pump (PN 6/PN 10)! — 1 = 1~ 230 V single-phase, 3 = 3~ 400 V three-phase

Check separately whether existing switchgears can be used.

Wilo Replacement Guide Heating

Grundfos

Single-head pumps



DN
Type

PN

Motor

Overall length
[mm]

Wilo – new



High-efficiency pumps

Infinitely variable, 1 ~ 230V, 50Hz
Stratos $T_{min} = -10^{\circ}C / T_{max} = 110^{\circ}C$
Stratos ECO $T_{min} = +15^{\circ}C / T_{max} = 110^{\circ}C$

Type

Motor
Overall length
[mm]

Adapter/
Remark



Energy-saving pumps*)

Infinitely variable, 1 ~ 230V,
50Hz
 $T_{max} = 95^{\circ}C$ or $110^{\circ}C$

Type

Motor
Overall length
[mm]

Adapter/
Remark



Standard pumps*)

1-/3-/4-stages
1 ~ 230V or 3 ~ 400V, 50Hz
 $T_{max} = 110^{\circ}C$ or $130^{\circ}C / 140^{\circ}C$

Type

Motor
Overall length
[mm]

Adapter/
Remark

Rp 1 (Pump thread G 1½)

Grundfos Model	PN	Motor	Overall length [mm]	Wilo Model	Motor	Overall length [mm]	Adapter/Remark	Wilo Model	Motor	Overall length [mm]	Adapter/Remark
UPM 20-35	10	1	180	Stratos ECO 25/1-3	1	180	-	Star-E 25/1-3	1	180	-
UPS 25-20x18	10	1	130	Stratos ECO 25/1-5-130	1	130	-	Star-E 25/1-3-130	1	130	-
UPS 15-20x20	10	1	180	Stratos ECO 25/1-3	1	180	-	Star-E 25/1-3	1	180	-
UPS 15-35x18	10	1	130	Stratos ECO 25/1-5-130	1	130	-	Star-E 25/1-3-130	1	130	-
UPS 15-35x20	10	1	180	Stratos ECO 25/1-3	1	180	-	Star-E 25/1-3	1	180	-
UPS 15-45x18	10	1	130	Stratos ECO 25/1-5-130	1	130	-	Star-E 25/1-5-130	1	130	-
UPS 15-45x20	10	1	180	Stratos ECO 25/1-5	1	180	-	Star-E 25/1-5	1	180	-
UPS 15-50 x18	10	1	130	Stratos ECO 25/1-5-130	1	130	-	Star-E 25/1-5-130	1	130	-
UPS 18-35	10	1	130	Stratos ECO 25/1-5-130	1	130	-	Star-E 25/1-5-130	1	130	-
UPS 18-45	10	1	130	Stratos ECO 25/1-5-130	1	130	-	Star-E 25/1-5-130	1	130	-
UPS 18-60	10	1	130	Stratos ECO 25/1-5-130	1	130	-	Star-E 25/1-5-130	1	130	-
UPS 19-35	10	1	160	Stratos ECO 25/1-5-130	1	130	R1	Star-E 25/1-5-130	1	130	R1
UPS 19-45	10	1	160	Stratos ECO 25/1-5-130	1	130	R1	Star-E 25/1-5-130	1	130	R1
UPS 19-60	10	1	160	Stratos ECO 25/1-5-130	1	130	R1	Star-E 25/1-5-130	1	130	R1
UPS 20-35	10	1	180	Stratos ECO 25/1-5	1	180	-	Star-E 25/1-5	1	180	-
UPS 20-45	10	1	180	Stratos ECO 25/1-5	1	180	-	Star-E 25/1-5	1	180	-
UPS 20-60	10	1	180	Stratos ECO 25/1-5	1	180	-	Star-E 25/1-5	1	180	-
UPS 25-120	10	1	180	Stratos 30/1-12	1	180	Mod. pipe	TOP-E 30/1-10	1	180	Mod. pipe
UPS 25-20	10	1	180	Stratos ECO 25/1-3	1	180	-	Star-E 25/1-3	1	180	-
UPS 25-25	10	1	180	Stratos ECO 25/1-3	1	180	-	Star-E 25/1-3	1	180	-
UPS 25-30	10	1	180	Stratos ECO 25/1-3	1	180	-	Star-E 25/1-3	1	180	-
UPS 25-40	10	1/3	180	Stratos ECO 25/1-5	1	180	-	Star-E 25/1-5	1	180	-
UPS 25-40 130	10	1	130	Stratos ECO 25/1-5-130	1	130	-	Star-E 25/1-5-130	1	130	-
UPS 25-50	10	1/3	180	Stratos ECO 25/1-5	1	180	-	Star-E 25/1-5	1	180	-
UPS 25-50 130	10	1	130	Stratos ECO 25/1-5-130	1	130	-	Star-E 25/1-5-130	1	130	-
UPS 25-60	10	1/3	180	Stratos ECO 25/1-5	1	180	-	Star-E 25/1-5	1	180	-
UPS 25-60 130	10	1	130	Stratos ECO 25/1-5-130	1	130	-	Star-E 25/1-5-130	1	130	-
UPS 25-80	10	1	180	Stratos 25/1-8	1	180	-	TOP-E 25/1-7	1	180	-
UPS 25-40 A	10	1	180	Stratos ECO-L 25/1-5	1	180	-	-	-	-	-
UPS 25-60 A	10	1	180	Stratos ECO-L 25/1-5	1	180	-	-	-	-	-
Alpha+ 25-40 A	10	1	180	Stratos ECO-L 25/1-5	1	180	-	-	-	-	-
Alpha+ 25-60 A	10	1	180	Stratos ECO-L 25/1-5	1	180	-	-	-	-	-
UPE 25-40 A	10	1	180	Stratos ECO-L 25/1-5	1	180	-	-	-	-	-
UPE 25-60 A	10	1	180	Stratos ECO-L 25/1-5	1	180	-	-	-	-	-
UPS 22-35	10	1	180	-	-	-	-	-	-	Star-RSL 25/6	1 180 -
UPS 22-45	10	1	180	-	-	-	-	-	-	Star-RSL 25/6	1 180 -
UPS 22-60	10	1	180	-	-	-	-	-	-	Star-RSL 25/6	1 180 -
UPS 23-35	10	1	180	-	-	-	-	-	-	Star-RSL 25/6	1 180 -
UPS 23-45	10	1	180	-	-	-	-	-	-	Star-RSL 25/6	1 180 -
UPS 23-60	10	1	180	-	-	-	-	-	-	Star-RSL 25/6	1 180 -
UPS 25-20 A/V	10	1	180	-	-	-	-	-	-	Star-RSL 25/6	1 180 -
UPS 25-30 A	10	1	180	-	-	-	-	-	-	Star-RSL 25/6	1 180 -

Rp 1 (Pump thread G 1½) Venting pumps

Grundfos Model	PN	Motor	Overall length [mm]	Wilo Model	Motor	Overall length [mm]	Adapter/Remark	Wilo Model	Motor	Overall length [mm]	Adapter/Remark
Alpha Pro 25-40 A	10	1	180	Stratos ECO-L 25/1-5	1	180	-	-	-	-	-
Alpha Pro 25-60 A	10	1	180	Stratos ECO-L 25/1-5	1	180	-	-	-	-	-
Alpha+ 25-40 A	10	1	180	Stratos ECO-L 25/1-5	1	180	-	-	-	-	-
Alpha+ 25-60 A	10	1	180	Stratos ECO-L 25/1-5	1	180	-	-	-	-	-
UPE 25-40 A	10	1	180	Stratos ECO-L 25/1-5	1	180	-	-	-	-	-
UPE 25-60 A	10	1	180	Stratos ECO-L 25/1-5	1	180	-	-	-	-	-
UPS 22-35	10	1	180	-	-	-	-	-	-	Star-RSL 25/6	1 180 -
UPS 22-45	10	1	180	-	-	-	-	-	-	Star-RSL 25/6	1 180 -
UPS 22-60	10	1	180	-	-	-	-	-	-	Star-RSL 25/6	1 180 -
UPS 23-35	10	1	180	-	-	-	-	-	-	Star-RSL 25/6	1 180 -
UPS 23-45	10	1	180	-	-	-	-	-	-	Star-RSL 25/6	1 180 -
UPS 23-60	10	1	180	-	-	-	-	-	-	Star-RSL 25/6	1 180 -
UPS 25-20 A/V	10	1	180	-	-	-	-	-	-	Star-RSL 25/6	1 180 -
UPS 25-30 A	10	1	180	-	-	-	-	-	-	Star-RSL 25/6	1 180 -

*) Energy efficiency class for each type see page 3-5

■ = Replacement pumps in accordance with EnEV (German Energy Saving Ordinance)

Observe current type (three-phase/single-phase) and nominal pressure of pump (PN 6/PN 10)! — 1 = 1 ~ 230 V single-phase, 3 = 3 ~ 400 V three-phase

Check separately whether existing switchgears can be used.

Grundfos				Wilo – new											
Single-head pumps				High-efficiency pumps				Energy-saving pumps ^{*)}				Standard pumps ^{*)}			
				 Infinitely variable, 1~230V, 50Hz Stratos T _{min} : -10°C/T _{max} : 110°C Stratos ECO T _{min} : +15°C/T _{max} : 110°C				 Infinitely variable, 1~230V, 50Hz T _{max} = 95°C or 110°C				 1-3-/4-stages 1~230V or 3~400V, 50Hz T _{max} = 110°C or 130°C/140°C			
DN Type	PN	Motor	Overall length [mm]	Type	Motor	Overall length [mm]	Adapter/Remark	Type	Motor	Overall length [mm]	Adapter/Remark	Type	Motor	Overall length [mm]	Adapter/Remark

Rp 1 (Pump thread G 1½) Venting pumps

UPS 25-40 A/V	10	1	180	-	-	-	-	-	-	-	-	Star-RSL 25/6	1	180	-
UPS 25-60 A/V	10	1	180	-	-	-	-	-	-	-	-	Star-RSL 25/6	1	180	-

Rp 1¼ (Pump thread G 2)

Alpha 32-40	10	1	180	Stratos ECO 30/1-3	1	180	-	Star-E 30/1-3	1	180	-	-	-	-	-
Alpha 32-60	10	1	180	Stratos ECO 30/1-5	1	180	-	Star-E 30/1-5	1	180	-	-	-	-	-
Alpha Pro 32-40	10	1	180	Stratos ECO 30/1-3	1	180	-	Star-E 30/1-3	1	180	-	-	-	-	-
Alpha Pro 32-60	10	1	180	Stratos ECO 30/1-5	1	180	-	Star-E 30/1-5	1	180	-	-	-	-	-
Alpha+ 32-40	10	1	180	Stratos ECO 30/1-3	1	180	-	Star-E 30/1-3	1	180	-	-	-	-	-
Alpha+ 32-60	10	1	180	Stratos ECO 30/1-5	1	180	-	Star-E 30/1-5	1	180	-	-	-	-	-
GD 30	10	1/3	206	Stratos ECO 30/1-5	1	180	R9	Star-E 30/1-5	1	180	R9	TOP-D 30	1/3	180	R9
Magna 32-100	10	1	180	Stratos 30/1-8	1	180	-	-	-	-	-	-	-	-	R8
Magna 32-100 N	10	1	180	Stratos-Z 30/1-8	1	180	-	-	-	-	-	-	-	-	-
Magna 32-60	10	1	180	Stratos 30/1-6	1	180	-	-	-	-	-	-	-	-	-
UM 32-20	10	3	180	-	-	-	-	-	-	-	-	RP 30/80 r	1/3	180	-
UM 32-20	10	3	200	-	-	-	-	-	-	-	-	RP 30/80 r	1/3	180	R8
UM 36-20 R	10	1	200	Stratos ECO 30/1-5	1	180	R8	Star-E 30/1-5	1	180	R8	Star-RS 30/4	1	180	R8
UM 36-20 R	10	3	200	-	-	-	-	-	-	-	-	RP 30/80 r	1/3	180	R8
UMS 32-20	10	1	200	Stratos ECO 30/1-5	1	180	R8	Star-E 30/1-5	1	180	R8	Star-RS 30/4	1	180	R8
UMS 32-20	10	1	180	Stratos ECO 30/1-5	1	180	-	Star-E 30/1-5	1	180	-	Star-RS 30/4	1	180	-
UMS 36-20 R	10	1	200	Stratos ECO 30/1-5	1	180	R8	Star-E 30/1-5	1	180	R8	Star-RS 30/4	1	180	R8
UP 32-25	10	3	180	Stratos ECO 30/1-3	1	180	-	Star-E 30/1-3	1	180	-	Star-RS 30/4	1	180	-
UP 32-50 G	10	3	200	Stratos 30/1-6	1	180	R8	TOP-E 30/1-7	1	180	R8	TOP-S 30/4	1/3	180	R8
UP 32-55 (G)	10	3	180	Stratos 30/1-6	1	180	-	TOP-E 30/1-7	1	180	-	TOP-S 30/4	1/3	180	-
UP 32-80	10	3	180	Stratos 30/1-12	1	180	-	TOP-E 30/1-10	1	180	-	TOP-S 30/10	1/3	180	-
UP 40-75 R	10	1/3	180	Stratos 30/1-12	1	180	-	TOP-E 30/1-10	1	180	-	TOP-S 30/10	1/3	180	-
UP 40-80 R	10	1/3	180	Stratos 30/1-12	1	180	-	TOP-E 30/1-10	1	180	-	TOP-S 30/10	1/3	180	-
UP 42-42 R	10	1/3	200	Stratos 30/1-8	1	180	R8	TOP-E 30/1-7	1	180	R8	TOP-S 30/7	1/3	180	R8
UP 42-50 R	10	1/3	200	Stratos 30/1-8	1	180	R8	TOP-E 30/1-7	1	180	R8	TOP-S 30/7	1/3	180	R8
UPE 32-25	10	1	180	Stratos ECO 30/1-3	1	180	-	Star-E 30/1-3	1	180	-	-	-	-	-
UPE 32-40	10	1	180	Stratos ECO 30/1-3	1	180	-	Star-E 30/1-3	1	180	-	-	-	-	-
UPE 32-45	10	1	180	Stratos ECO 30/1-5	1	180	-	Star-E 30/1-5	1	180	-	-	-	-	-
UPE 32-60	10	1	180	Stratos ECO 30/1-5	1	180	-	Star-E 30/1-5	1	180	-	-	-	-	-
UPE 32-80	10	1	180	Stratos 30/1-8	1	180	-	TOP-E 30/1-7	1	180	-	-	-	-	-
UPS 15-20x40	10	1	180	Stratos ECO 30/1-3	1	180	-	Star-E 30/1-3	1	180	-	Star-RS 30/2	1	180	-
UPS 15-35x40	10	1	180	Stratos ECO 30/1-3	1	180	-	Star-E 30/1-3	1	180	-	Star-RS 30/4	1	180	-
UPS 15-45x40	10	1	180	Stratos ECO 30/1-5	1	180	-	Star-E 30/1-5	1	180	-	Star-RS 30/4	1	180	-
UPS 32-20	10	1	180	Stratos ECO 30/1-3	1	180	-	Star-E 30/1-3	1	180	-	Star-RS 30/2	1	180	-
UPS 32-25	10	1	180	Stratos ECO 30/1-3	1	180	-	Star-E 30/1-3	1	180	-	Star-RS 30/4	1	180	-
UPS 32-30	10	1	180	Stratos ECO 30/1-3	1	180	-	Star-E 30/1-3	1	180	-	Star-RS 30/4	1	180	-

^{*)} Energy efficiency class for each type see page 3-5

= Replacement pumps in accordance with EnEV (German Energy Saving Ordinance)

Observe current type (three-phase/single-phase) and nominal pressure of pump (PN 6/PN 10)! — 1 = 1~230 V single-phase, 3 = 3~400 V three-phase

Check separately whether existing switchgears can be used.

Wilo Replacement Guide Heating

Grundfos

Single-head pumps



DN
Type

PN

Motor

Overall length
[mm]

Wilo – new



High-efficiency pumps

Infinitely variable, 1 ~ 230V, 50Hz
Stratos $T_{min}: -10^{\circ}C/T_{max}: 110^{\circ}C$
Stratos ECO $T_{min}: +15^{\circ}C/T_{max}: 110^{\circ}C$

Type

Motor
Overall length
[mm]

Adapter/
Remark



Energy-saving pumps*)

Infinitely variable, 1 ~ 230V,
50Hz
 $T_{max} = 95^{\circ}C$ or $110^{\circ}C$

Type

Motor
Overall length
[mm]

Adapter/
Remark



Standard pumps*)

1-/3-/4-stages
1 ~ 230V or 3 ~ 400V, 50Hz
 $T_{max} = 110^{\circ}C$ or $130^{\circ}C/140^{\circ}C$

Type

Motor
Overall length
[mm]

Adapter/
Remark

Rp 1¼ (Pump thread G 2)

Grundfos Model	PN	Motor	Overall length [mm]	Wilo Model	Motor	Overall length [mm]	Adapter/Remark	Wilo Model	Motor	Overall length [mm]	Adapter/Remark
UPS 32-40	10	1	180	Stratos ECO 30/1-3	1	180	-	Star-E 30/1-3	1	180	-
UPS 32-50	10	1	180	Stratos 30/1-6	1	180	-	Star-E 30/1-5	1	180	-
UPS 32-50 G	10	1	200	Stratos 30/1-8	1	180	R8	TOP-E 30/1-7	1	180	R8
UPS 32-55 (G)	10	1	180	Stratos 30/1-8	1	180	-	TOP-E 30/1-7	1	180	-
UPS 32-60	10	1	180	Stratos 30/1-6	1	180	-	Star-E 30/1-5	1	180	-
UPS 32-80	10	1	180	Stratos 30/1-12	1	180	-	TOP-E 30/1-10	1	180	-
UPS 40-35	10	1	180	Stratos ECO 30/1-5	1	180	-	Star-E 30/1-5	1	180	-
UPS 40-45	10	1	180	Stratos ECO 30/1-5	1	180	-	Star-E 30/1-5	1	180	-
UPS 40-80 R	10	1	180	Stratos 30/1-12	1	180	-	TOP-E 30/1-10	1	180	-
UPS 42-50 R	10	1	200	Stratos 30/1-8	1	180	R8	TOP-E 30/1-7	1	180	R8

DN 25 Oval flange

Grundfos Model	PN	Motor	Overall length [mm]	Wilo Model	Motor	Overall length [mm]	Adapter/Remark	Wilo Model	Motor	Overall length [mm]	Adapter/Remark
UM 21-15	10	1	120	Stratos ECO 25/1-5-130	1	130	Mod. pipe	Star-E 25/1-3-130	1	130	Mod. pipe
UM 21-20 (V)	10	1/3	120	Stratos ECO 25/1-5-130	1	130	Mod. pipe	Star-E 25/1-3-130	1	130	Mod. pipe
UM 21-20 (V)	10	3	120	-	-	-	-	-	-	-	-
UMS 21-20	10	1	120	Stratos ECO 25/1-5-130	1	130	Mod. pipe	Star-E 25/1-5	1	180	Mod. pipe
UP 21-20 (V)	10	1	120	Stratos ECO 25/1-5-130	1	130	Mod. pipe	Star-E 25/1-5	1	180	Mod. pipe
UP 21-35 (V)	10	1	120	Stratos ECO 25/1-5-130	1	130	Mod. pipe	Star-E 25/1-5	1	180	Mod. pipe
UP 21-35 (V)	10	3	120	-	-	-	-	-	-	-	-
UPS 15-35x21	10	1	120	Stratos ECO 25/1-5-130	1	130	Mod. pipe	Star-E 25/1-5	1	180	Mod. pipe
UPS 15-45x21	10	1	120	Stratos ECO 25/1-5-130	1	130	Mod. pipe	Star-E 25/1-5	1	180	Mod. pipe
UPS 21-35	10	1	120	Stratos ECO 25/1-5-130	1	130	Mod. pipe	Star-E 25/1-5	1	180	Mod. pipe
UPS 21-40	10	1	120	Stratos ECO 25/1-5-130	1	130	Mod. pipe	Star-E 25/1-5	1	180	Mod. pipe
UPS 21-45	10	1	120	Stratos ECO 25/1-5-130	1	130	Mod. pipe	Star-E 25/1-5	1	180	Mod. pipe
UPS 21-60 F	10	1	120	Stratos ECO 25/1-5-130	1	130	Mod. pipe	Star-E 25/1-5	1	180	Mod. pipe

DN 32 (Square flange)

Grundfos Model	PN	Motor	Overall length [mm]	Wilo Model	Motor	Overall length [mm]	Adapter/Remark	Wilo Model	Motor	Overall length [mm]	Adapter/Remark
UM 36-20 F	10	1	200	Stratos ECO 30/1-5	1	180	2 x RF8	Star-E 30/1-5	1	180	2 x RF8
UM 36-20 F	10	3	200	-	-	-	-	-	-	-	-
UM 40-12 F	10	1	200	Stratos ECO 30/1-3	1	180	2 x RF8	Star-E 30/1-3	1	180	2 x RF8
UM 40-12 F	10	3	200	-	-	-	-	-	-	-	-
UM 40-18 F	10	1	200	Stratos ECO 30/1-3	1	180	2 x RF8	Star-E 30/1-3	1	180	2 x RF8
UM 40-18 F	10	3	200	-	-	-	-	-	-	-	-

DN 32

Grundfos Model	PN	Motor	Overall length [mm]	Wilo Model	Motor	Overall length [mm]	Adapter/Remark	Wilo Model	Motor	Overall length [mm]	Adapter/Remark
Magna 32-100 F	6/10	1	220	Stratos 30/1-8	1	180	2 x RF3(PN6)	-	-	-	-
Magna 32-120 F	6/10	1	220	Stratos 32/1-12	1	220	-	-	-	-	-
Magna 32-120 FN	6/10	1	220	Stratos-Z 30/1-12	1	180	2 x RF3(PN6)	-	-	-	-
Magna UPE 32-120 F	6/10	1	220	Stratos 32/1-12	1	220	-	TOP-E 30/1-10	1	180	2 x RF3(PN6)
Magna UPE 32-120 FB	6/10	1	220	Stratos-Z 30/1-12	1	180	2 x RF3(PN6)	-	-	-	-
Magna UPE 32-120 FN	6/10	1	220	Stratos-Z 30/1-12	1	180	2 x RF3(PN6)	-	-	-	-
UMC 32-30	6/10	1/3	220	Stratos 30/1-6	1	180	2 x RF3(PN6)	TOP-E 30/1-7	1	180	2 x RF3(PN6)
UMK 32-30	6/10	1/3	220	Stratos 30/1-6	1	180	2 x RF3(PN6)	-	-	-	-

*) Energy efficiency class for each type see page 3-5

■ = Replacement pumps in accordance with EnEV (German Energy Saving Ordinance)

Observe current type (three-phase/single-phase) and nominal pressure of pump (PN 6/PN 10)! — 1 = 1 ~ 230 V single-phase, 3 = 3 ~ 400 V three-phase

Check separately whether existing switchgears can be used.

Grundfos				Wilo – new											
Single-head pumps				High-efficiency pumps				Energy-saving pumps*)				Standard pumps*)			
				Infinitely variable, 1~ 230V, 50Hz Stratos $T_{min}: -10^{\circ}C/T_{max}: 110^{\circ}C$ Stratos ECO $T_{min}: +15^{\circ}C/T_{max}: 110^{\circ}C$				Infinitely variable, 1~ 230V, 50Hz $T_{max} = 95^{\circ}C$ or $110^{\circ}C$				1-3-/4-stages 1~ 230V or 3~ 400V, 50Hz $T_{max} = 110^{\circ}C$ or $130^{\circ}C/140^{\circ}C$			
DN Type	PN	Motor	Overall length [mm]	Type	Motor	Overall length [mm]	Adapter/Remark	Type	Motor	Overall length [mm]	Adapter/Remark	Type	Motor	Overall length [mm]	Adapter/Remark
DN 32															
UPC 32-120	6/10	1/3	220	Stratos 32/1-12	1	220	-	TOP-E 30/1-10	1	180	2 x RF3(PN6)	TOP-S 30/10	1/3	180	2 x RF3(PN6)
UPC 32-60	6/10	1/3	220	Stratos 32/1-12	1	220	-	TOP-E 30/1-10	1	180	2 x RF3(PN6)	TOP-S 30/7	1/3	180	2 x RF3(PN6)
UPE 32-120 FB	6/10	1	220	Stratos-Z 30/1-12	1	180	2 x RF3(PN6)	-	-	-	-	-	-	-	-
UPE 32-120(F)	6/10	1	220	Stratos 32/1-12	1	220	-	TOP-E 30/1-10	1	180	2 x RF3(PN6)	-	-	-	-
UPE 32-80 F	6/10	1	220	Stratos 32/1-12	1	220	-	TOP-E 30/1-7	1	180	2 x RF3(PN6)	-	-	-	-
UPE 32-80 FB	6/10	1	220	-	-	-	-	TOP-E 30/1-7 (RG)	1	180	2 x RF3	-	-	-	-
UPK 32-120	6/10	1/3	220	Stratos 32/1-12	1	220	-	-	-	-	-	TOP-S 30/10	1/3	180	2 x RF3(PN6)
UPK 32-60	6/10	1/3	220	Stratos 32/1-12	1	220	-	-	-	-	-	TOP-S 30/10	1/3	180	2 x RF3(PN6)
UPS 32-120 F	6/10	1/3	220	Stratos 32/1-12	1	220	-	TOP-E 40/1-10	1	250	Mod. pipe	TOP-S 40/10	3	250	F1
UPS 32-30 F	6/10	1/3	220	Stratos 30/1-8	1	180	2 x RF3(PN6)	TOP-E 30/1-7	1	180	2 x RF3(PN6)	RP 30/100 r	1/3	180	-
UPS 32-60 F	6/10	1/3	220	Stratos 32/1-12	1	220	-	TOP-E 40/1-4	1	220	Mod. pipe	TOP-S 30/10	1/3	180	2 x RF3(PN6)
UPS 32-80 F	6/10	1	220	Stratos 32/1-12	1	220	-	TOP-E 30/1-10	1	180	2 x RF3(PN6)	TOP-S 30/10	1/3	180	2 x RF3(PN6)
DN 40															
GD 40	6/10	1/3	220	-	-	-	-	Star-E 25/1-5	1	180	2 x RF9(PN6)	TOP-D 40	1/3	220	-
Magna 40-100 F	6/10	1	220	Stratos 40/1-8	1	220	-	-	-	-	-	-	-	-	-
Magna 40-120 F	6/10	1	250	Stratos 40/1-12	1	250	-	-	-	-	-	-	-	-	-
Magna 40-120 FN	6/10	1	250	Stratos-Z 40/1-12	1	250	-	-	-	-	-	-	-	-	-
Magna UPE 40-120 F	6/10	1	250	Stratos 40/1-12	1	250	-	TOP-E 40/1-10	1	250	-	-	-	-	-
Magna UPE 40-120 FB	6/10	1	250	Stratos-Z 40/1-12	1	250	-	-	-	-	-	-	-	-	-
Magna UPE 40-120 FN	6/10	1	250	Stratos-Z 40/1-12	1	250	-	-	-	-	-	-	-	-	-
UMC 40-30	6/10	1/3	250	Stratos 40/1-4	1	220	F1	TOP-E 40/1-4	1	220	F1	TOP-S 40/4	1/3	220	F1
UMC 40-60	6/10	1/3	250	Stratos 40/1-8	1	220	F1	TOP-E 40/1-10	1	250	-	TOP-S 40/7	1/3	250	-
UMK 40-30	6/10	1/3	250	Stratos 40/1-4	1	220	F1	-	-	-	-	TOP-S 40/4	1/3	220	F1
UMK 40-60	6/10	1/3	250	Stratos 40/1-8	1	220	F1	-	-	-	-	TOP-S 40/7	1/3	250	-
UMS 40-30	6/10	1/3	250	Stratos 40/1-4	1	220	F1	TOP-E 40/1-4	1	220	F1	TOP-S 40/4	1/3	220	F1
UP 40-50 F	6/10	3	250	Stratos 40/1-4	1	220	F1	TOP-E 40/1-4	1	220	F1	TOP-S 40/4	1/3	220	-
UP 40-80 F	6/10	3	250	Stratos 40/1-8	1	220	F1	TOP-E 40/1-10	1	250	-	TOP-S 40/7	1/3	250	-
UP 42-42 F	6/10	1/3	250	Stratos 40/1-4	1	220	F1	TOP-E 40/1-4	1	220	F1	TOP-S 40/4	1/3	220	F1
UP 42-50 F	6/10	1/3	250	Stratos 40/1-4	1	220	F1	TOP-E 40/1-4	1	220	F1	TOP-S 40/4	1/3	220	F1
UPC 40-120	6/10	1/3	250	Stratos 40/1-12	1	250	-	TOP-E 40/1-10	1	250	-	TOP-S 40/10	3	250	-
UPC 40-60	6/10	1/3	250	Stratos 40/1-8	1	220	F1	TOP-E 40/1-10	1	250	-	TOP-S 40/7	1/3	250	-
UPE 40-120 (F)	6/10	1	250	Stratos 40/1-8	1	220	F1	TOP-E 40/1-10	1	250	-	-	-	-	-
UPE 40-120 (FB)	6/10	1	250	Stratos-Z 40/1-8	1	220	F1	-	-	-	-	-	-	-	-
UPE 40-80 (F)	6/10	1	250	Stratos 40/1-8	1	220	F1	TOP-E 40/1-4	1	220	F1	-	-	-	-
UPK 40-120	6/10	1/3	250	Stratos 40/1-12	1	250	-	IP-E 40/115-0,55/2	3	250	-	TOP-S 40/7	1/3	250	-
UPK 40-180	6/10	1/3	250	-	-	-	-	IP-E 40/115-0,55/2	3	250	-	-	-	-	-
UPK 40-60	6/10	1/3	250	Stratos 40/1-8	1	220	F1	-	-	-	-	TOP-S 40/7	1/3	250	-
UPS 40-120 (F)	6/10	1/3	250	Stratos 40/1-8	1	220	F1	TOP-E 40/1-10	1	250	-	TOP-S 40/10	3	250	-
UPS 40-120 FB	6/10	1/3	250	Stratos-Z 40/1-8	1	220	F1	-	-	-	-	-	-	-	-

*) Energy efficiency class for each type see page 3-5

■ = Replacement pumps in accordance with EnEV (German Energy Saving Ordinance)

Observe current type (three-phase/single-phase) and nominal pressure of pump (PN 6/PN 10)! — 1 = 1~ 230 V single-phase, 3 = 3~ 400 V three-phase

Check separately whether existing switchgears can be used.

Wilo Replacement Guide Heating

Grundfos

Single-head pumps



DN
Type

PN
Motor
Overall length
[mm]

Wilo – new



High-efficiency pumps

Infinitely variable, 1 ~ 230V, 50Hz
Stratos $T_{min} = -10^{\circ}C / T_{max} = 110^{\circ}C$
Stratos ECO $T_{min} = +15^{\circ}C / T_{max} = 110^{\circ}C$



Energy-saving pumps*)

Infinitely variable, 1 ~ 230V,
50Hz
 $T_{max} = 95^{\circ}C$ or $110^{\circ}C$



Standard pumps*)

1-/3-/4-stages
1 ~ 230V or 3 ~ 400V, 50Hz
 $T_{max} = 110^{\circ}C$ or $130^{\circ}C / 140^{\circ}C$

Type

Motor
Overall length
[mm]
Adapter/
Remark

Type

Motor
Overall length
[mm]
Adapter/
Remark

Type

Motor
Overall length
[mm]
Adapter/
Remark

DN 40

Grundfos	PN	Motor	Overall length [mm]	Wilo – new	Motor	Overall length [mm]	Adapter/Remark	Wilo – new	Motor	Overall length [mm]	Adapter/Remark	Wilo – new	Motor	Overall length [mm]	Adapter/Remark
UPS 40-180 F	6/10	1/3	250	Stratos 50/1-12	1	280	Mod. pipe	TOP-E 50/1-10	1	280	Mod. pipe	TOP-S 40/15	3	250	-
UPS 40-185 F	6/10	1/3	250	-	-	-	-	IP-E 40/115-0,55/2	3	250	-	TOP-S 40/15	3	250	-
UPS 40-30 F	6/10	1/3	250	Stratos 40/1-4	1	220	F1	TOP-E 40/1-4	1	220	F1	TOP-S 40/4	1/3	220	F1
UPS 40-50 F	6/10	1	250	Stratos 40/1-4	1	220	F1	TOP-E 40/1-4	1	220	F1	TOP-S 40/4	1/3	220	F1
UPS 40-60	6/10	1/3	250	Stratos 40/1-8	1	220	F1	TOP-E 40/1-10	1	250	-	TOP-S 40/7	1/3	250	-
UPS 40-60/2 F	6/10	1/3	250	Stratos 40/1-8	1	220	F1	TOP-E 40/1-10	1	250	-	TOP-S 40/7	1/3	250	-
UPS 40-60/4 F	6/10	1/3	250	Stratos 40/1-8	1	220	F1	TOP-E 40/1-10	1	250	-	TOP-S 40/7	1/3	250	-
UPS 40-80 F	6/10	1	250	Stratos 40/1-8	1	220	F1	TOP-E 40/1-10	1	250	-	TOP-S 40/7	1/3	250	-
UPS 42-50 F	6/10	1	250	Stratos 40/1-4	1	220	F1	TOP-E 40/1-4	1	220	F1	TOP-S 40/4	1/3	220	F1
UPS 42-80 F	6/10	1	250	Stratos 40/1-8	1	220	F1	TOP-E 40/1-10	1	250	-	TOP-S 40/7	1/3	250	-

DN 50

GD 50	6/10	1/3	240	-	-	-	-	-	-	-	-	TOP-D 50	1/3	240	-
Magna 50-100 F	6/10	1	280	Stratos 50/1-8	1	240	2xF3	-	-	-	-	-	-	-	-
Magna 50-120 F	6/10	1	280	Stratos 50/1-9	1	280	-	-	-	-	-	-	-	-	-
Magna 50-120 FN	6/10	1	280	Stratos-Z 50/1-9	1	280	-	-	-	-	-	-	-	-	-
Magna 50-60 F	6/10	1	280	Stratos 50/1-8	1	240	2xF3	-	-	-	-	-	-	-	-
Magna 50-60 FN	6/10	1	280	Stratos-Z 50/1-9	1	280	-	-	-	-	-	-	-	-	-
Magna UPE 50-120 F	6/10	1	280	Stratos 50/1-9	1	280	-	TOP-E 50/1-10	1	280	-	-	-	-	-
Magna UPE 50-120 FN	6/10	1	280	Stratos-Z 50/1-9	1	280	-	-	-	-	-	-	-	-	-
Magna UPE 50-60 F	6/10	1	280	Stratos 50/1-8	1	240	2xF3	TOP-E 50/1-7	1	280	-	-	-	-	-
Magna UPE 50-60 FB	6/10	1	280	Stratos-Z 50/1-9	1	280	-	TOP-E 50/1-7 (RG)	1	280	-	-	-	-	-
Magna UPE 50-60 FN	6/10	1	280	Stratos-Z 50/1-9	1	280	-	TOP-E 50/1-7 (RG)	1	280	-	-	-	-	-
UMC 50-30	6/10	1/3	280	Stratos 50/1-8	1	240	2xF3	TOP-E 50/1-6	1	240	2xF3	TOP-S 50/4	1/3	240	2xF3
UMC 50-60	6/10	1/3	280	Stratos 50/1-8	1	240	2xF3	TOP-E 50/1-6	1	240	2xF3	TOP-S 50/4	1/3	240	2xF3
UMK 50-30	6/10	1/3	280	Stratos 50/1-8	1	240	2xF3	-	-	-	-	TOP-S 50/4	1/3	240	2xF3
UMK 50-60	6/10	1/3	280	Stratos 50/1-9	1	280	-	-	-	-	-	TOP-S 50/4	1/3	240	2xF3
UMS 50-30	6/10	1/3	280	Stratos 50/1-8	1	240	2xF3	TOP-E 50/1-6	1	240	2xF3	TOP-S 50/4	1/3	240	2xF3
UMS 50-60	6/10	1/3	280	Stratos 50/1-8	1	240	2xF3	TOP-E 50/1-6	1	240	2xF3	TOP-S 50/4	1/3	240	2xF3
UPC 50-120	6/10	1/3	280	Stratos 50/1-12	1	280	-	TOP-E 50/1-10	1	280	-	TOP-S 50/10	3	280	-
UPC 50-60	6/10	1/3	280	Stratos 50/1-9	1	280	-	TOP-E 50/1-7	1	280	-	TOP-S 50/7	3	280	-
UPE 50-120 (F)	6/10	3	280	Stratos 50/1-12	1	280	-	TOP-E 50/1-10	1	280	-	-	-	-	-
UPE 50-120 FB	6/10	3	280	Stratos-Z 50/1-9	1	280	-	-	-	-	-	-	-	-	-
UPE 50-60 (F)	6/10	1	280	Stratos 50/1-8	1	240	2xF3	TOP-E 50/1-6	1	240	2xF3	-	-	-	-
UPE 50-60 (F)B	6/10	1	250	Stratos-Z 50/1-9	1	280	Mod. pipe	TOP-E 50/1-7 (RG)	1	280	Mod. pipe	-	-	-	-
UPE 50-80 (F)	6/10	1	280	Stratos 50/1-9	1	280	-	TOP-E-50/1-7	1	280	-	-	-	-	-
UPE 50-80 (F)B	6/10	1	280	Stratos-Z 50/1-9	1	280	-	TOP-E 50/1-7 (RG)	1	280	-	-	-	-	-

*) Energy efficiency class for each type see page 3-5

■ = Replacement pumps in accordance with EnEV (German Energy Saving Ordinance)

Observe current type (three-phase/single-phase) and nominal pressure of pump (PN 6/PN 10)! — 1 = 1 ~ 230 V single-phase, 3 = 3 ~ 400 V three-phase

Check separately whether existing switchgears can be used.

Grundfos				Wilo – new												
Single-head pumps				High-efficiency pumps				Energy-saving pumps*)				Standard pumps*)				
Single-head pumps				Infinitely variable, 1~230V, 50Hz				Infinitely variable, 1~230V, 50Hz				1-3-/4-stages				
Single-head pumps				Stratos T _{min} : -10°C/T _{max} : 110°C				T _{max} = 95°C or 110°C				1~230V or 3~400V, 50Hz				
Single-head pumps				Stratos ECO T _{min} : +15°C/T _{max} : 110°C								T _{max} = 110°C or 130°C/140°C				
DN	Type	PN	Motor	Overall length [mm]	Type	Motor	Overall length [mm]	Adapter/Remark	Type	Motor	Overall length [mm]	Adapter/Remark	Type	Motor	Overall length [mm]	Adapter/Remark
DN 50																
UPK 50-120		6/10	1/3	280	Stratos 50/1-12	1	280	-	IP-E 50/115-0,75/2	3	280	-	TOP-S 50/10	3	280	-
UPK 50-180		6/10	1/3	280	Stratos 50/1-12	1	280	-	IP-E 50/115-0,75/2	3	280	-	P 50/250 r	3	440	Mod. pipe
UPK 50-60		6/10	1/3	280	Stratos 50/1-9	1	280	-	-	-	-	-	TOP-S 50/4	1/3	240	2xF3
UPS 50-120 (F)		6/10	1/3	280	Stratos 50/1-12	1	280	-	TOP-E 50/1-10	1	280	-	TOP-S 50/10	3	280	-
UPS 50-180 F		6/10	1/3	280	Stratos 50/1-12	1	280	-	IP-E 50/115-0,75/2	3	280	-	TOP-S 50/10	3	280	-
UPS 50-185 F		6/10	1/3	280	-	-	-	-	IP-E 50/115-0,75/2	3	280	-	TOP-S 50/15	3	340	Mod. pipe
UPS 50-30 F		6/10	1/3	280	Stratos 50/1-8	1	240	2xF3	TOP-E 50/1-6	1	240	2xF3	TOP-S 50/4	1/3	240	2xF3
UPS 50-60		6/10	3	280	Stratos 50/1-9	1	280	-	TOP-E 50/1-6	1	240	2xF3	TOP-S 50/4	1/3	240	2xF3
UPS 50-60/2 F		6/10	1/3	280	Stratos 50/1-9	1	280	-	TOP-E 50/1-7	1	280	-	TOP-S 50/7	3	280	-
UPS 50-60/4 F		6/10	1/3	280	Stratos 50/1-8	1	240	2xF3	TOP-E 50/1-7	1	280	-	TOP-S 50/7	3	280	-
DN 65																
GD 65		6/10	1/3	280	-	-	-	-	-	-	-	-	TOP-D 65	1/3	280	-
Magna 65-120 F		6/10	1	340	Stratos 65/1-12	1	340	-	-	-	-	-	-	-	-	-
Magna 65-120 FN		6/10	1	340	-	-	-	-	TOP-E 65/1-10 (RG)	1	340	-	-	-	-	-
Magna 65-60 F		6/10	1	340	Stratos 65/1-9	1	280	2xF11	-	-	-	-	-	-	-	-
Magna 65-60 FN		6/10	1	340	-	-	-	-	TOP-E 65/1-10 (RG)	1	340	-	-	-	-	-
Magna UPE 65-120 F		6/10	1	340	Stratos 65/1-12	1	340	-	TOP-E 65/1-10	1	340	-	-	-	-	-
Magna UPE 65-120 FN		6/10	1	340	-	-	-	-	TOP-E 65/1-10 (RG)	1	340	-	-	-	-	-
Magna UPE 65-60 F		6/10	1	340	Stratos 65/1-9	1	280	2xF11	TOP-E 65/1-10	1	340	-	-	-	-	-
Magna UPE 65-60 FB		6/10	1	340	-	-	-	-	TOP-E 65/1-10 (RG)	1	340	-	-	-	-	-
Magna UPE 65-60 FN		6/10	1	340	-	-	-	-	TOP-E 65/1-10 (RG)	1	340	-	-	-	-	-
UM 65-26		6/10	1/3	340	Stratos 65/1-9	1	280	2xF11	TOP-E 65/1-10	1	340	-	TOP-S 65/7	3	280	2xF11
UMC 65-30		6/10	1/3	340	Stratos 65/1-9	1	280	2xF11	TOP-E 65/1-10	1	340	-	TOP-S 65/7	3	280	2xF11
UMC 65-60		6/10	1/3	340	Stratos 65/1-9	1	280	2xF11	TOP-E 65/1-10	1	340	-	TOP-S 65/7	3	280	2xF11
UMK 65-30		6/10	1/3	340	Stratos 65/1-9	1	280	2xF11	-	-	-	-	TOP-S 65/7	3	280	2xF11
UMK 65-60		6/10	1/3	340	Stratos 65/1-9	1	280	2xF11	-	-	-	-	TOP-S 65/7	3	280	2xF11
UMS 65-30		6/10	1/3	340	Stratos 65/1-9	1	280	2xF11	TOP-E 65/1-10	1	340	-	TOP-S 65/7	3	280	-
UMS 65-60		6/10	1/3	340	Stratos 65/1-9	1	280	2xF11	TOP-E 65/1-10	1	340	-	TOP-S 65/7	3	280	-
UP 65-75		6/10	3	340	Stratos 65/1-9	1	280	2xF11	TOP-E 65/1-10	1	340	-	TOP-S 65/7	3	280	2xF11
UP 65-79		6/10	3	340	Stratos 65/1-9	1	280	2xF11	TOP-E 65/1-10	1	340	-	TOP-S 65/10	3	340	-
UP 65-90		6/10	3	340	Stratos 65/1-9	1	280	2xF11	TOP-E 65/1-10	1	340	-	TOP-S 65/10	3	340	-
UPC 65-120		6/10	1/3	340	Stratos 65/1-12	1	340	-	IP-E 65/115-1,5/2	3	340	-	TOP-S 65/13	3	340	-
UPC 65-60		6/10	3	340	Stratos 65/1-9	1	280	2xF11	TOP-E 65/1-10	1	340	-	TOP-S 65/7	3	280	2xF11
UPE 65-120 (F)		6/10	3	340	Stratos 65/1-12	1	340	-	TOP-E 65/1-10	1	340	-	-	-	-	-
UPE 65-120 FB		6/10	3	340	-	-	-	-	TOP-E 65/1-10 (RG)	1	340	-	-	-	-	-
UPE 65-60 (F)		6/10	1	340	Stratos 65/1-9	1	280	2xF11	TOP-E 65/1-10	1	340	-	-	-	-	-
UPE 65-60 FB		6/10	1	340	-	-	-	-	TOP-E 65/1-10 (RG)	1	340	-	-	-	-	-

*) Energy efficiency class for each type see page 3-5

■ = Replacement pumps in accordance with EnEV (German Energy Saving Ordinance)

Observe current type (three-phase/single-phase) and nominal pressure of pump (PN 6/PN 10)! — 1 = 1~230 V single-phase, 3 = 3~400 V three-phase

Check separately whether existing switchgears can be used.

Wilo Replacement Guide Heating

Grundfos

Single-head pumps



DN
Type

PN Motor Overall length [mm]

Wilo – new



High-efficiency pumps

Infinitely variable, 1 ~ 230V, 50Hz
Stratos $T_{min}: -10^{\circ}C/T_{max}: 110^{\circ}C$
Stratos ECO $T_{min}: +15^{\circ}C/T_{max}: 110^{\circ}C$

Type

Motor Overall length [mm] Adapter/Remark



Energy-saving pumps*)

Infinitely variable, 1 ~ 230V, 50Hz
 $T_{max} = 95^{\circ}C$ or $110^{\circ}C$

Type

Motor Overall length [mm] Adapter/Remark



Standard pumps*)

1-/3-/4-stages
1 ~ 230V or 3 ~ 400V, 50Hz
 $T_{max} = 110^{\circ}C$ or $130^{\circ}C/140^{\circ}C$

Type

Motor Overall length [mm] Adapter/Remark

DN 65

Grundfos Model	PN	Motor	Overall length [mm]	Wilo High-efficiency Type	Wilo High-efficiency Motor	Wilo High-efficiency Overall length [mm]	Wilo High-efficiency Adapter/Remark	Wilo Energy-saving Type	Wilo Energy-saving Motor	Wilo Energy-saving Overall length [mm]	Wilo Energy-saving Adapter/Remark	Wilo Standard Type	Wilo Standard Motor	Wilo Standard Overall length [mm]	Wilo Standard Adapter/Remark
UPK 65-120	6/10	1/3	340	-	-	-	-	IP-E 65/115-1,5/2	3	340	-	TOP-S 65/13	3	340	-
UPK 65-180	6/10	3	340	-	-	-	-	IP-E 65/115-1,5/2	3	340	-	P 65/250 r	3	475	Mod. pipe
UPK 65-60	6/10	1/3	340	Stratos 65/1-9	1	280	2xF11	-	-	-	-	TOP-S 65/7	3	280	2xF11
UPS 65-120 (F)	6/10	1/3	340	Stratos 65/1-12	1	340	-	IP-E 65/115-1,5/2	3	340	-	TOP-S 65/13	3	340	-
UPS 65-180 F	6/10	1/3	340	-	-	-	-	IP-E 65/115-1,5/2	3	340	-	TOP-S 65/15	3	340	-
UPS 65-185 F	6/10	3	340	-	-	-	-	IP-E 65/115-1,5/2	3	340	-	TOP-S 65/15	3	340	-
UPS 65-30 F	6/10	1/3	340	Stratos 65/1-9	1	280	2xF11	TOP-E 65/1-10	1	340	-	TOP-S 65/7	3	280	2xF11
UPS 65-60	6/10	3	340	Stratos 65/1-9	1	280	2xF11	TOP-E 65/1-10	1	340	-	TOP-S 65/7	3	280	2xF11
UPS 65-60/2 F	6/10	3	340	Stratos 65/1-9	1	280	2xF11	TOP-E 65/1-10	1	340	-	TOP-S 65/7	3	280	2xF11
UPS 65-60/4 F	6/10	1/3	340	Stratos 65/1-9	1	280	2xF11	TOP-E 65/1-10	1	340	-	TOP-S 65/7	3	280	2xF11

DN 80

Grundfos Model	PN	Motor	Overall length [mm]	Wilo High-efficiency Type	Wilo High-efficiency Motor	Wilo High-efficiency Overall length [mm]	Wilo High-efficiency Adapter/Remark	Wilo Energy-saving Type	Wilo Energy-saving Motor	Wilo Energy-saving Overall length [mm]	Wilo Energy-saving Adapter/Remark	Wilo Standard Type	Wilo Standard Motor	Wilo Standard Overall length [mm]	Wilo Standard Adapter/Remark
GD 80	6/10	1/3	330	-	-	-	-	-	-	-	-	TOP-D 80	1/3	330	-
UM 80-50	6/10	3	360	Stratos 80/1-12	1	360	-	TOP-E 80/1-10	1	360	-	TOP-S 80/7	3	360	-
UMC 80-30	6/10	3	360	Stratos 80/1-12	1	360	-	TOP-E 80/1-10	1	360	-	TOP-S 80/7	3	360	-
UMC 80-60	6/10	3	360	Stratos 80/1-12	1	360	-	TOP-E 80/1-10	1	360	-	TOP-S 80/10	3	360	-
UMK 80-30	6/10	3	360	Stratos 80/1-12	1	360	-	-	-	-	-	TOP-S 80/7	3	360	-
UMK 80-60	6/10	3	360	Stratos 80/1-12	1	360	-	-	-	-	-	TOP-S 80/10	3	360	-
UMS 80-30	6/10	3	360	Stratos 80/1-12	1	360	-	TOP-E 80/1-10	1	360	-	TOP-S 80/7	3	360	-
UMS 80-60	6/10	3	360	Stratos 80/1-12	1	360	-	TOP-E 80/1-10	1	360	-	TOP-S 80/10	3	360	-
UP 80-113	6/10	3	360	Stratos 80/1-12	1	360	-	TOP-E 80/1-10	1	360	-	TOP-S 80/10	3	360	-
UP 80-96	6/10	3	360	Stratos 80/1-12	1	360	-	TOP-E 80/1-10	1	360	-	TOP-S 80/10	3	360	-
UPC 80-120	6/10	3	360	Stratos 80/1-12	1	360	-	TOP-E 80/1-10	1	360	-	TOP-S 80/10	3	360	-
UPE 80-120 (F)	6/10	3	360	Stratos 80/1-12	1	360	-	TOP-E 80/1-10	1	360	-	-	-	-	-
UPE 80-120 FB	6/10	3	360	-	-	-	-	TOP-E 80/1-10 (RG)	1	360	-	-	-	-	-
UPK 80-120	6/10	3	360	Stratos 80/1-12	1	360	-	IP-E 80/115-2,2/2	3	360	-	TOP-S 80/10	3	360	-
UPS 80-120 F	6/10	3	360	Stratos 80/1-12	1	360	-	TOP-E 80/1-10	1	360	-	TOP-S 80/10	3	360	-
UPS 80-30 F	6/10	3	360	Stratos 80/1-12	1	360	-	TOP-E 80/1-10	1	360	-	TOP-S 80/7	3	360	-
UPS 80-60 F	6/10	3	360	Stratos 80/1-12	1	360	-	TOP-E 80/1-10	1	360	-	TOP-S 80/10	3	360	-

*) Energy efficiency class for each type see page 3-5

■ = Replacement pumps in accordance with EnEV (German Energy Saving Ordinance)

Observe current type (three-phase/single-phase) and nominal pressure of pump (PN 6/PN 10)! — 1 = 1 ~ 230 V single-phase, 3 = 3 ~ 400 V three-phase

Check separately whether existing switchgears can be used.

Grundfos				Wilo – new											
Single-head pumps				High-efficiency pumps Infinitely variable, 1~230V, 50Hz Stratos $T_{min}: -10^{\circ}C/T_{max}: 110^{\circ}C$ Stratos ECO $T_{min}: +15^{\circ}C/T_{max}: 110^{\circ}C$				Energy-saving pumps^{*)} Infinitely variable, 1~230V, 50Hz $T_{max} = 95^{\circ}C$ or $110^{\circ}C$				Standard pumps^{*)} 1-/3-/4-stages 1~230V or 3~400V, 50Hz $T_{max} = 110^{\circ}C$ or $130^{\circ}C/140^{\circ}C$			
DN Type	PN	Motor	Overall length [mm]	Type	Motor	Overall length [mm]	Adapter/Remark	Type	Motor	Overall length [mm]	Adapter/Remark	Type	Motor	Overall length [mm]	Adapter/Remark
DN 100															
GD 100	6/10	1/3	380	–	–	–	–	–	–	–	–	TOP-D 100	1/3	380	–
UMC 100-30	6/10	3	450	Stratos 100/1-12	1	360 (F34+F35) (PN6)	–	TOP-E 100/1-10	1	360 (F34+F35) (PN6)	–	P 100/160 r	3	395	F35(PN6)
UMC 100-60	6/10	3	450	Stratos 100/1-12	1	360 (F34+F35) (PN6)	–	TOP-E 100/1-10	1	360 (F34+F35) (PN6)	–	P 100/160 r	3	395	F35(PN6)
UMK 100-30	6/10	3	450	Stratos 100/1-12	1	360 (F34+F35) (PN6)	–	–	–	–	–	P 100/160 r	3	395	F35(PN6)
UMK 100-60	6/10	3	450	Stratos 100/1-12	1	360 (F34+F35) (PN6)	–	–	–	–	–	P 100/160 r	3	395	F35(PN6)
UMS 100-30	6/10	3	450	Stratos 100/1-12	1	360 (F34+F35) (PN6)	–	TOP-E 100/1-10	1	360 (F34+F35) (PN6)	–	P 100/160 r	3	395	F35(PN6)
UMS 100-60	6/10	3	450	Stratos 100/1-12	1	360 (F34+F35) (PN6)	–	TOP-E 100/1-10	1	360 (F34+F35) (PN6)	–	P 100/160 r	3	395	F35(PN6)
UPE 100-60 F	6/10	3	450	Stratos 100/1-12	1	360 (F34+F35) (PN6)	–	TOP-E 100/1-10	1	360 (F34+F35) (PN6)	–	–	–	–	–
UPE 100-60 F	6/10	3	450	–	–	–	–	–	–	–	–	–	–	–	–
UPS 100-30 F	6/10	3	450	Stratos 100/1-12	1	360 (F34+F35) (PN6)	–	TOP-E 100/1-10	1	360 (F34+F35) (PN6)	–	P 100/160 r	3	395	2 x RF3(PN6)
DN 125															
GD 125	6/10	3	450	–	–	–	–	–	–	–	–	TOP-D 125	3	450	–

^{*)} Energy efficiency class for each type see page 3–5

= Replacement pumps in accordance with EnEV (German Energy Saving Ordinance)

Observe current type (three-phase/single-phase) and nominal pressure of pump (PN 6/PN 10)! — 1 = 1~230 V single-phase, 3 = 3~400 V three-phase

Check separately whether existing switchgears can be used.

Wilo Replacement Guide Heating

Grundfos

Twin-head pumps



DN
Type

PN
Motor
Overall length
[mm]

Wilo – new

High-efficiency pumps
 Infinitely variable, 1 ~ 230V, 50Hz
 Stratos $T_{min} = -10^{\circ}C / T_{max} = 110^{\circ}C$
 Stratos ECO $T_{min} = +15^{\circ}C / T_{max} = 110^{\circ}C$

Energy-saving pumps*)
 Infinitely variable, 1 ~ 230V,
 50Hz
 $T_{max} = 95^{\circ}C$ or $110^{\circ}C$

Standard pumps*)
 1-/3-/4-stages
 1 ~ 230V or 3 ~ 400V, 50Hz
 $T_{max} = 110^{\circ}C$ or $130^{\circ}C / 140^{\circ}C$

Type
Motor
Overall length
[mm]
Adapter/
Remark

Type
Motor
Overall length
[mm]
Adapter/
Remark

Type
Motor
Overall length
[mm]
Adapter/
Remark

DN 32

Magna UPED 32-120 F	6/10	1	220	Stratos-D 32/1-12	1	220	-	-	-	-	-	-	-	
Magna-D 32-120 F	6/10	1	220	Stratos-D 32/1-12	1	220	-	-	-	-	-	-	-	
UMCD 32-30	6/10	1/3	220	Stratos-D 32/1-8	1	220	-	-	-	-	DOP 40/100 r	1/3	250 Mod. pipe	
UMKD 32-30	6/10	1/3	220	Stratos-D 32/1-8	1	220	-	-	-	-	DOP 40/100 r	1/3	250 Mod. pipe	
UPCD 32-120	6/10	1/3	220	Stratos-D 32/1-12	1	220	-	TOP-ED 40/1-10	1	250	Mod. pipe	TOP-SD 40/10	3	250 Mod. pipe
UPCD 32-60	6/10	1/3	220	Stratos-D 32/1-12	1	220	-	TOP-ED 40/1-7	1	250	Mod. pipe	TOP-SD 40/7	1/3	250 Mod. pipe
UPD 32-35	6/10	3	220	Stratos-D 32/1-8	1	220	-	TOP-ED 32/1-7	1	220	-	Star-RSD 30/4	1	180 2 x RF3(PN6)
UPD 32-50 (F)	6/10	3	220	Stratos-D 32/1-8	1	220	-	TOP-ED 32/1-7	1	220	-	TOP-SD 32/7	1/3	220 -
UPD 32-80 F	6/10	3	220	Stratos-D 32/1-8	1	220	-	TOP-ED 32/1-7	1	220	-	TOP-SD 32/7	1/3	220 -
UPED 32-120 F	6/10	1	220	Stratos-D 32/1-12	1	220	-	TOP-ED 40/1-10	1	250	Mod. pipe	TOP-SD 40/10	3	250 Mod. pipe
UPKD 32-120	6/10	1/3	220	Stratos-D 32/1-12	1	220	-	-	-	-	-	TOP-SD 40/10	3	250 Mod. pipe
UPKD 32-60	6/10	1/3	220	Stratos-D 32/1-12	1	220	-	-	-	-	-	TOP-SD 40/7	1/3	250 Mod. pipe
UPSD 32-120 F	6/10	1/3	220	Stratos-D 32/1-12	1	220	-	TOP-ED 40/1-10	1	250	Mod. pipe	TOP-SD 40/10	3	250 Mod. pipe
UPSD 32-30 F	6/10	1/3	220	Stratos-D 32/1-8	1	220	-	TOP-ED 32/1-7	1	220	-	DOP 40/100 r	1/3	250 -
UPSD 32-35	6/10	1	220	Stratos-D 32/1-8	1	220	-	TOP-ED 32/1-7	1	220	-	Star-RSD 30/4	1	180 -
UPSD 32-45	6/10	1	220	Stratos-D 32/1-8	1	220	-	TOP-ED 32/1-7	1	220	-	Star-RSD 30/6	1	180 2 x RF3(PN6)
UPSD 32-50 F	6/10	1	220	Stratos-D 32/1-8	1	220	-	TOP-ED 32/1-7	1	220	-	TOP-SD 32/7	1/3	220 -
UPSD 32-60 F	6/10	1/3	220	Stratos-D 32/1-8	1	220	-	TOP-ED 40/1-7	1	250	Mod. pipe	TOP-SD 40/7	1/3	250 Mod. pipe
UPSD 32-80 F	6/10	1	220	Stratos-D 32/1-8	1	220	-	TOP-ED 32/1-7	1	220	-	TOP-SD 32/7	1/3	220 -

DN 40

Magna UPED 40-120 F	6/10	1	250	Stratos-D 40/1-12	1	250	-	-	-	-	-	-	-	
Magna D 40-100 F	6/10	1	250	Stratos-D 40/1-8	1	220	F1	-	-	-	-	-	-	
Magna-D 40-120 F	6/10	1	250	Stratos-D 40/1-12	1	250	-	-	-	-	-	-	-	
UMCD 40-30	6/10	1/3	250	Stratos-D 40/1-8	1	220	F1	TOP-ED 40/1-7	1	250	-	DOP 40/100 r	1/3	250 -
UMKD 40-30	6/10	1/3	250	Stratos-D 40/1-8	1	220	F1	-	-	-	-	DOP 40/100 r	1/3	250 -
UMSD 40-30	6/10	1/3	250	Stratos-D 40/1-8	1	220	F1	TOP-ED 40/1-7	1	250	-	DOP 40/100 r	1/3	250 -
UPCD 40-120	6/10	1/3	250	Stratos-D 40/1-12	1	250	-	TOP-ED 40/1-10	1	250	-	TOP-SD 40/10	3	250 -
UPCD 40-60	6/10	1/3	250	Stratos-D 40/1-8	1	220	F1	TOP-ED 40/1-7	1	250	-	TOP-SD 40/7	1/3	250 -
UPD 40-50 F	6/10	3	250	Stratos-D 40/1-8	1	220	F1	TOP-ED 40/1-7	1	250	-	TOP-SD 40/7	1/3	250 -
UPD 40-80 F	6	3	250	Stratos-D 40/1-8	1	220	F1	TOP-ED 40/1-7	1	250	-	TOP-SD 40/7	1/3	250 -
UPD 42-42	6/10	1/3	250	Stratos-D 40/1-8	1	220	F1	TOP-ED 40/1-7	1	250	-	DOP 40/100 r	1/3	250 -
UPD 42-50	6/10	3	250	Stratos-D 40/1-8	1	220	F1	TOP-ED 40/1-7	1	250	-	TOP-SD 40/7	1/3	250 -
UPD 42-80 F	6	3	250	Stratos-D 40/1-8	1	220	F1	TOP-ED 40/1-7	1	250	-	TOP-SD 40/7	1/3	250 -
UPED 40-120 F	6/10	1	250	Stratos-D 40/1-12	1	250	-	TOP-ED 40/1-10	1	250	-	-	-	-
UPKD 40-120	6/10	1/3	250	Stratos-D 40/1-12	1	250	-	-	-	-	-	TOP-SD 40/10	3	250 -
UPKD 40-60	6/10	1/3	250	Stratos-D 40/1-8	1	220	F1	-	-	-	-	TOP-SD 40/7	1/3	250 -
UPSD 40-120 F	6/10	1/3	250	Stratos-D 40/1-12	1	250	-	TOP-ED 40/1-10	1	250	-	TOP-SD 40/10	3	250 -
UPSD 40-30 F	6/10	1/3	250	Stratos-D 40/1-8	1	220	F1	TOP-ED 40/1-7	1	250	-	DOP 40/100 r	1/3	250 -
UPSD 40-50 F	6/10	1	250	Stratos-D 40/1-8	1	220	F1	TOP-ED 40/1-7	1	250	-	TOP-SD 40/7	1/3	250 -
UPSD 40-60 F	6/10	1/3	250	Stratos-D 40/1-8	1	220	F1	TOP-ED 40/1-7	1	250	-	TOP-SD 40/7	1/3	250 -
UPSD 40-60/2 F	6/10	1/3	250	Stratos-D 40/1-8	1	220	F1	TOP-ED 40/1-7	1	250	-	TOP-SD 40/7	1/3	250 -
UPSD 40-80 F	6	1	250	Stratos-D 40/1-8	1	220	F1	TOP-ED 40/1-7	1	250	-	TOP-SD 40/7	1/3	250 -
UPSD 42-50	6/10	1	250	Stratos-D 40/1-8	1	220	F1	TOP-ED 40/1-7	1	250	-	TOP-SD 40/7	1/3	250 -

*) Energy efficiency class for each type see page 3-5

■ = Replacement pumps in accordance with EnEV (German Energy Saving Ordinance)

Observe current type (three-phase/single-phase) and nominal pressure of pump (PN 6/PN 10)! — 1 = 1 ~ 230 V single-phase, 3 = 3 ~ 400 V three-phase

Check separately whether existing switchgears can be used.

Grundfos			Wilo – new								
Twin-head pumps			High-efficiency pumps Infinitely variable, 1~ 230V, 50Hz Stratos $T_{min}: -10^{\circ}C/T_{max}: 110^{\circ}C$ Stratos ECO $T_{min}: +15^{\circ}C/T_{max}: 110^{\circ}C$			Energy-saving pumps*) Infinitely variable, 1~ 230V, 50Hz $T_{max} = 95^{\circ}C$ or $110^{\circ}C$			Standard pumps*) 1-3-/4-stages 1~ 230V or 3~ 400V, 50Hz $T_{max} = 110^{\circ}C$ or $130^{\circ}C/140^{\circ}C$		
DN Type	PN	Motor Overall length [mm]	Type	Motor Overall length [mm]	Adapter/Remark	Type	Motor Overall length [mm]	Adapter/Remark	Type	Motor Overall length [mm]	Adapter/Remark

DN 50											
Magna UPED 50-60 F	6/10	1 280	Stratos-D 50/1-8	1 240	2x F3	TOP-ED 50/1-7	1 280	-	-	-	-
Magna-D 50-120 F	6/10	1 280	Stratos-D 50/1-12	1 280	-	-	-	-	-	-	-
Magna-D 50-60 F	6/10	1 280	Stratos-D 50/1-8	1 240	2x F3	-	-	-	-	-	-
UMCD 50-30	6/10	1/3 280	Stratos-D 50/1-8	1 240	2x F3	TOP-ED 50/1-7	1 280	-	DOP 50/100 r	3 280	-
UMCD 50-60	6/10	1/3 280	Stratos-D 50/1-9	1 280	-	TOP-ED 50/1-7	1 280	-	TOP-SD 50/7	3 280	-
UMKD 50-30	6/10	1/3 280	Stratos-D 50/1-8	1 240	2x F3	-	-	-	DOP 50/100 r	3 280	-
UMKD 50-60	6/10	1/3 280	Stratos-D 50/1-9	1 280	-	-	-	-	TOP-SD 50/7	3 280	-
UMSD 50-30	6/10	1/3 280	Stratos-D 50/1-8	1 240	2x F3	TOP-ED 50/1-7	1 280	-	DOP 50/100 r	3 280	-
UMSD 50-60	6/10	1/3 280	Stratos-D 50/1-9	1 280	-	TOP-ED 50/1-7	1 280	-	DOP 50/160 r	3 340	Mod. pipe
UPCD 50-120	6/10	1/3 280	-	-	-	DP-E 50/115-0,75/2-3	3 280	-	TOP-SD 50/10	3 280	-
UPCD 50-60	6/10	1/3 280	Stratos-D 50/1-9	1 280	-	TOP-ED 50/1-7	1 280	-	TOP-SD 50/7	3 280	-
UPD 50-60	6/10	1/3 280	Stratos-D 50/1-8	1 240	2x F3	TOP-ED 50/1-6	1 240	2x F3	DOP 50/160 r	3 340	Mod. pipe
UPED 50-120 F	6/10	3 280	Stratos-D 50/1-12	1 280	-	TOP-ED 50/1-10	1 280	-	-	-	-
UPED 50-60 F	6/10	1 280	Stratos-D 50/1-9	1 280	-	TOP-ED 50/1-7	1 280	-	-	-	-
UPKD 50-120	6/10	1/3 280	-	-	-	DP-E 50/115-0,75/2-3	3 280	-	TOP-SD 50/10	3 280	-
UPKD 50-180	6/10	1/3 280	-	-	-	DP-E 50/115-0,75/2-3	3 280	-	-	-	-
UPKD 50-60	6/10	1/3 280	Stratos-D 50/1-9	1 280	-	-	-	-	TOP-SD 50/7	3 280	-
UPSD 50-120 (F)	6/10	1/3 280	Stratos-D 50/1-12	1 280	-	TOP-ED 50/1-10	1 280	-	TOP-SD 50/10	3 280	-
UPSD 50-180 F	6/10	1/3 280	Stratos-D 65/1-12	1 340	Mod. pipe	DP-E 50/115-0,75/2-3	3 280	-	TOP-SD 65/13	3 340	-
UPSD 50-30 F	6/10	1/3 280	Stratos-D 50/1-8	1 240	2x F3	TOP-ED 50/1-6	1 240	2x F3	DOP 50/100 r	3 280	-
UPSD 50-60	6/10	3 280	Stratos-D 50/1-8	1 240	2x F3	TOP-ED 50/1-6	1 240	2x F3	DOP 50/160 r	3 340	Mod. pipe
UPSD 50-60/2 F	6/10	1/3 280	Stratos-D 50/1-9	1 280	-	TOP-ED 50/1-7	1 280	-	TOP-SD 50/7	3 280	-
UPSD 50-60/4 F	6/10	1/3 280	Stratos-D 50/1-9	1 280	-	TOP-ED 50/1-7	1 280	-	TOP-SD 50/7	3 280	-

DN 65											
Magna UPED 65-60 F	6/10	1 340	Stratos-D 65/1-12	1 340	-	TOP-ED 65/1-10	1 340	-	-	-	-
Magna-D 65-120 F	6/10	1 340	Stratos-D 65/1-12	1 340	-	-	-	-	-	-	-
Magna-D 65-60 F	6/10	1 340	Stratos-D 65/1-12	1 340	-	-	-	-	-	-	-
UMCD 65-30	6/10	1/3 340	Stratos-D 65/1-12	1 340	-	TOP-ED 65/1-10	1 340	-	DOP 65/125 r	3 340	-
UMCD 65-60	6/10	1/3 340	Stratos-D 65/1-12	1 340	-	TOP-ED 65/1-10	1 340	-	DOP 65/125 r	3 340	-
UMD 65-26	6/10	1/3 340	Stratos-D 65/1-12	1 340	-	-	-	-	DOP 65/125 r	3 340	-
UMKD 65-30	6/10	1/3 340	Stratos-D 65/1-12	1 340	-	-	-	-	DOP 65/125 r	3 340	-
UMKD 65-60	6/10	1/3 340	Stratos-D 65/1-12	1 340	-	-	-	-	DOP 65/125 r	3 340	-
UMSD 65-30	6/10	1/3 340	Stratos-D 65/1-12	1 340	-	-	-	-	DOP 65/125 r	3 340	-
UMSD 65-60	6/10	1/3 340	Stratos-D 65/1-12	1 340	-	TOP-ED 65/1-10	1 340	-	DOP 65/125 r	3 340	-
UPCD 65-120	6/10	1/3 340	Stratos-D 65/1-12	1 340	-	DP-E 65/115-1,5/2	3 340	-	TOP-SD 65/13	3 340	-
UPCD 65-60	6/10	1/3 340	Stratos-D 65/1-12	1 340	-	TOP-ED 65/1-10	1 340	-	TOP-SD 65/10	3 340	-
UPD 65-75	6/10	3 340	Stratos-D 65/1-12	1 340	-	TOP-ED 65/1-10	1 340	-	TOP-SD 65/10	3 340	-
UPD 65-79	6/10	3 340	Stratos-D 65/1-12	1 340	-	-	-	-	TOP-SD 65/10	3 340	-
UPD 65-90	6/10	3 340	Stratos-D 65/1-12	1 340	-	-	-	-	TOP-SD 65/10	3 340	-



*) Energy efficiency class for each type see page 3-5

= Replacement pumps in accordance with EnEV (German Energy Saving Ordinance)

Observe current type (three-phase/single-phase) and nominal pressure of pump (PN 6/PN 10)! — 1 = 1~ 230 V single-phase, 3 = 3~ 400 V three-phase

Check separately whether existing switchgears can be used.

Wilo Replacement Guide Heating

Grundfos				Wilo – new												
Twin-head pumps				 High-efficiency pumps Infinitely variable, 1 ~ 230V, 50Hz Stratos $T_{min}: -10^{\circ}C/T_{max}: 110^{\circ}C$ Stratos ECO $T_{min}: +15^{\circ}C/T_{max}: 110^{\circ}C$				 Energy-saving pumps*) Infinitely variable, 1 ~ 230V, 50Hz $T_{max} = 95^{\circ}C$ or $110^{\circ}C$				 Standard pumps*) 1-/3-/4-stages 1 ~ 230V or 3 ~ 400V, 50Hz $T_{max} = 110^{\circ}C$ or $130^{\circ}C/140^{\circ}C$				
DN	Type	PN	Motor	Overall length [mm]	Type	Motor	Overall length [mm]	Adapter/Remark	Type	Motor	Overall length [mm]	Adapter/Remark	Type	Motor	Overall length [mm]	Adapter/Remark
DN 65																
	UPED 65-120 (F)	6/10	3	340	Stratos-D 65/1-12	1	340	-	TOP-ED 65/1-10	1	340	-	-	-	-	-
	UPED 65-60 F	6/10	1	340	Stratos-D 65/1-12	1	340	-	TOP-ED 65/1-10	1	340	-	-	-	-	-
	UPKD 65-120	6/10	1/3	340	-	-	-	-	DP-E 65/115-1,5/2	3	340	-	TOP-SD 65/13	3	340	-
	UPKD 65-180	6/10	3	340	-	-	-	-	DP-E 65/115-1,5/2	3	340	-	TOP-SD 65/15	3	340	-
	UPKD 65-60	6/10	1/3	340	Stratos-D 65/1-12	1	340	-	-	-	-	-	TOP-SD 65/10	3	340	-
	UPSD 65-120 (F)	6/10	1/3	340	-	-	-	-	DP-E 65/115-1,5/2	3	340	-	TOP-SD 65/13	3	340	-
	UPSD 65-180 F	6/10	3	340	-	-	-	-	DP-E 65/115-1,5/2	3	340	-	TOP-SD 65/15	3	340	-
	UPSD 65-30 F	6/10	1/3	340	Stratos-D 65/1-12	1	340	-	TOP-ED 65/1-10	1	340	-	DOP 65/125 r	3	340	-
	UPSD 65-60	6/10	3	340	Stratos-D 65/1-12	1	340	-	TOP-ED 65/1-10	1	340	-	TOP-SD 65/10	3	340	-
	UPSD 65-60/2 F	6/10	1/3	340	Stratos-D 65/1-12	1	340	-	TOP-ED 65/1-10	1	340	-	TOP-SD 65/10	3	340	-
	UPSD 65-60/4 F	6/10	1/3	340	Stratos-D 65/1-12	1	340	-	TOP-ED 65/1-10	1	340	-	TOP-SD 65/10	3	340	-
DN 80																
	UMCD 80-30	6/10	3	360	Stratos-D 80/1-12	1	360	-	TOP-ED 80/1-10	1	360	-	DOP 80/125 r	3	360	-
	UMCD 80-60	6/10	3	360	Stratos-D 80/1-12	1	360	-	TOP-ED 80/1-10	1	360	-	DOP 80/160 r	3	360	-
	UMD 80-50	6/10	3	360	Stratos-D 80/1-12	1	360	-	TOP-ED 80/1-10	1	360	-	DOP 80/125 r	3	360	-
	UMKD 80-30	6/10	3	360	Stratos-D 80/1-12	1	360	-	-	-	-	-	DOP 80/125 r	3	360	-
	UMKD 80-60	6/10	3	360	Stratos-D 80/1-12	1	360	-	-	-	-	-	DOP 80/160 r	3	360	-
	UMSD 80-30	6/10	3	360	Stratos-D 80/1-12	1	360	-	TOP-ED 80/1-10	1	360	-	DOP 80/125 r	3	360	-
	UMSD 80-60	6/10	3	360	Stratos-D 80/1-12	1	360	-	TOP-ED 80/1-10	1	360	-	DOP 80/125 r	3	360	-
	UPCD 80-120	6/10	3	360	Stratos-D 80/1-12	1	360	-	TOP-ED 80/1-10	1	360	-	TOP-SD 80/10	3	360	-
	UPD 80-113	6/10	3	360	Stratos-D 80/1-12	1	360	-	DP-E 80/115-2,2/2	3	360	-	TOP-SD 80/10	3	360	-
	UPD 80-96	6/10	3	360	Stratos-D 80/1-12	1	360	-	DP-E 80/115-2,2/2	3	360	-	TOP-SD 80/10	3	360	-
	UPED 80-120 (F)	6/10	3	360	Stratos-D 80/1-12	1	360	-	TOP-ED 80/1-10	1	360	-	-	-	-	-
	UPKD 80-120	6/10	3	360	Stratos-D 80/1-12	1	360	-	DP-E 80/115-2,2/2	3	360	-	TOP-SD 80/10	3	360	-
	UPSD 80-120 F	6/10	3	360	Stratos-D 80/1-12	1	360	-	DP-E 80/115-2,2/2	3	360	-	TOP-SD 80/10	3	360	-
	UPSD 80-30 F	6/10	3	360	Stratos-D 80/1-12	1	360	-	TOP-ED 80/1-10	1	360	-	DOP 80/125 r	3	360	-
	UPSD 80-60 F	6/10	3	360	Stratos-D 80/1-12	1	360	-	TOP-ED 80/1-10	1	360	-	DOP 80/160 r	3	360	-
DN 100																
	UMCD 100-30	6/10	3	450	-	-	-	-	-	-	-	-	DOP 100/160 r	3	395	F35(PN6)
	UMCD 100-60	6/10	3	450	-	-	-	-	-	-	-	-	DOP 100/160 r	3	395	F35(PN6)
	UMKD 100-30	6/10	3	450	-	-	-	-	-	-	-	-	DOP 100/160 r	3	395	F35(PN6)
	UMKD 100-60	6/10	3	450	-	-	-	-	-	-	-	-	DOP 100/160 r	3	395	F35(PN6)
	UMSD 100-30	6/10	3	450	-	-	-	-	-	-	-	-	DOP 100/160 r	3	395	F35(PN6)
	UMSD 100-60	6/10	3	450	-	-	-	-	-	-	-	-	DOP 100/160 r	3	395	F35(PN6)
	UPED 100-60 F	6/10	3	450	-	-	-	-	-	-	-	-	-	-	-	-
	UPSD 100-30 F	6/10	3	450	-	-	-	-	-	-	-	-	DOP 100/160 r	3	395	F35(PN6)

*) Energy efficiency class for each type see page 3-5

 = Replacement pumps in accordance with EnEV (German Energy Saving Ordinance)

Observe current type (three-phase/single-phase) and nominal pressure of pump (PN 6/PN 10)! — 1 = 1 ~ 230 V single-phase, 3 = 3 ~ 400 V three-phase

Check separately whether existing switchgears can be used.

KSB			Wilo – new								
Single-head pumps			High-efficiency pumps Infinitely variable, 1~ 230V, 50Hz Stratos $T_{min}: -10^{\circ}C/T_{max}: 110^{\circ}C$ Stratos ECO $T_{min}: +15^{\circ}C/T_{max}: 110^{\circ}C$			Energy-saving pumps*) Infinitely variable, 1~ 230V, 50Hz $T_{max} = 95^{\circ}C$ or $110^{\circ}C$			Standard pumps*) 1-/3-/4-stages 1~ 230V or 3~ 400V, 50Hz $T_{max} = 110^{\circ}C$ or $130^{\circ}C/140^{\circ}C$		
DN Type	PN	Motor Overall length [mm]	Type	Motor Overall length [mm]	Adapter/Remark	Type	Motor Overall length [mm]	Adapter/Remark	Type	Motor Overall length [mm]	Adapter/Remark

Rp ½ (Pump thread G 1)

C 02/40 Rio	10	1 130	–	–	–	Star-E 15/1-5-130	1 130	–	Star-RS 15/4-130	1 130	–
C 02/60 Rio	10	1 130	–	–	–	Star-E 15/1-5-130	1 130	–	Star-RS 15/6-130	1 130	–
C 15-15 130 Rio	10	1 130	–	–	–	Star-E 15/1-3-130	1 130	–	Star-RS 15/4-130	1 130	–
C 15-40 130 Rio	10	1 130	–	–	–	Star-E 15/1-3-130	1 130	–	Star-RS 15/4-130	1 130	–
C 15-60 130 Rio	10	1 130	–	–	–	Star-E 15/1-5-130	1 130	–	Star-RS 15/6-130	1 130	–

Rp ¾ (Pump thread G 1¼)

C 12/40 Rio	10	1 130	–	–	–	Star-E 25/1-3-130	1 130	Mod. pipe	Star-RS 25/4-130	1 130	–
C 12/60 Rio	10	1 130	–	–	–	Star-E 25/1-5-130	1 130	Mod. pipe	Star-RS 25/6-130	1 130	–

Rp 1 (Pump thread G 1½)

22-2 E 13 Riovar	10	1 130	Stratos ECO 25/1-5-130	1 130	–	Star-E 25/1-3-130	1 130	–	Star-RS 25/4-130	1 130	–
22-2 E 16 Riovar	10	1 160	Stratos ECO 25/1-5-130	1 130	R1	Star-E 25/1-5-130	1 130	R1	Star-RS 25/4-130	1 130	R1
22-2 E Riovar	10	1 180	Stratos ECO 25/1-3	1 180	–	Star-E 25/1-3	1 180	–	Star-RS 25/4	1 180	–
22-3 E 13 Riovar	10	1 130	Stratos ECO 25/1-5-130	1 130	–	Star-E 25/1-3-130	1 130	–	Star-RS 25/4-130	1 130	–
22-3 E Riovar	10	1 180	Stratos ECO 25/1-3	1 180	–	Star-E 25/1-3	1 180	–	Star-RS 25/4	1 180	–
22-4 E 13 Riovar	10	1 130	Stratos ECO 25/1-5-130	1 130	–	Star-E 25/1-5-130	1 130	–	Star-RS 25/6-130	1 130	–
22-4 E 16 Riovar	10	1 160	Stratos ECO 25/1-5-130	1 130	R1	Star-E 25/1-5-130	1 130	R1	Star-RS 25/6-130	1 130	R1
22-4 E Riovar	10	1 180	Stratos ECO 25/1-5	1 180	–	Star-E 25/1-5	1 180	–	Star-RS 25/6	1 180	–
22-5 E 13 Riovar	10	1 130	Stratos ECO 25/1-5-130	1 130	–	Star-E 25/1-5-130	1 130	–	Star-RS 25/6-130	1 130	–
22-5 E Riovar	10	1 180	Stratos ECO 25/1-5	1 180	–	Star-E 25/1-5	1 180	–	Star-RS 25/6	1 180	–
22-6 E/D Riovar	10	1/3 180	Stratos 25/1-6	1 180	–	TOP-E 25/1-7	1 180	–	TOP-S 25/7	1/3 180	–
22-7 E/D Riovar	10	1/3 180	Stratos 25/1-8	1 180	–	TOP-E 25/1-7	1 180	–	TOP-S 25/7	1/3 180	–
24-2 E/D Riovar	10	1 180	Stratos ECO 25/1-5	1 180	–	Star-E 25/1-5	1 180	–	Star-RS 25/4	1 180	–
24-2 E/D Riovar	10	3 180	–	–	–	–	–	–	RP 25/80 r	1/3 180	–
24-8 E/D Riovar	10	1 180	Stratos 25/1-6	1 180	–	TOP-E 25/1-7	1 180	–	Star-RS 25/6	1 180	–
24-8 E/D Riovar	10	3 180	–	–	–	–	–	–	RP 25/100 r	1/3 180	–
25-40 Riotronic	10	1 180	Stratos ECO 25/1-3	1 180	–	Star-E 25/1-3	1 180	–	–	–	–
25-60 B Riotronic	10	1 180	Stratos ECO 25/1-5-RG	1 180	–	–	–	–	–	–	–
25-60 Rio-Eco	10	1 180	Stratos 25/1-6	1 180	–	–	–	–	–	–	–
25-60 Riotronic	10	1 180	Stratos ECO 25/1-5	1 180	–	Star-E 25/1-5	1 180	–	–	–	–
25-60 Riotronic SSM	10	1 180	Stratos ECO 25/1-5-BMS	1 180	–	–	–	–	–	–	–
25-7 E/D Rio	10	1/3 180	Stratos 25/1-8	1 180	–	TOP-E 25/1-7	1 180	–	TOP-S 25/7	1/3 180	–
25-70 E/D Rio	10	1/3 180	Stratos 25/1-8	1 180	–	TOP-E 25/1-7	1 180	–	TOP-S 25/7	1/3 180	–
25-70 Riotec	10	1/3 180	Stratos 25/1-8	1 180	–	TOP-E 25/1-7	1 180	–	–	–	–
25-80 Rio-Eco	10	1 180	Stratos 25/1-8	1 180	–	–	–	–	–	–	–
A 2 V	10	1/3 180	Stratos 25/1-8	1 180	–	TOP-E 25/1-7	1 180	–	TOP-S 25/7	1/3 180	–
B 2 V	10	1 180	Stratos ECO 25/1-5	1 180	–	Star-E 25/1-5	1 180	–	Star-RS 25/6	1 180	–
C 2 V	10	1 180	Stratos ECO 25/1-5	1 180	–	Star-E 25/1-5	1 180	–	Star-RS 25/4	1 180	–
C 22/20 Riomatic	10	1 180	Stratos ECO 25/1-3	1 180	–	Star-E 25/1-3	1 180	–	–	–	–
C 22/25 Rio	10	1 180	Stratos ECO 25/1-3	1 180	–	Star-E 25/1-3	1 180	–	Star-RS 25/2	1 180	–
C 22/35 Riomatic	10	1 180	Stratos ECO 25/1-5	1 180	–	Star-E 25/1-5	1 180	–	–	–	–
C 22/40 Rio	10	1 180	Stratos ECO 25/1-3	1 180	–	Star-E 25/1-3	1 180	–	Star-RS 25/4	1 180	–
C 22/40-130 Rio	10	1 130	Stratos ECO 25/1-5	1 130	–	Star-E 25/1-3-130	1 130	–	Star-RS 25/4-130	1 130	–

*) Energy efficiency class for each type see page 3–5

■ = Replacement pumps in accordance with EnEV (German Energy Saving Ordinance)

Observe current type (three-phase/single-phase) and nominal pressure of pump (PN 6/PN 10)! — 1 = 1~ 230 V single-phase, 3 = 3~ 400 V three-phase

Check separately whether existing switchgears can be used.

Wilo Replacement Guide Heating

KSB

Single-head pumps



DN
Type

PN
Motor
Overall length
[mm]

Wilo – new



High-efficiency pumps

Infinitely variable, 1 ~ 230V, 50Hz
Stratos $T_{min} = -10^{\circ}C / T_{max} = 110^{\circ}C$
Stratos ECO $T_{min} = +15^{\circ}C / T_{max} = 110^{\circ}C$

Type

Motor
Overall length
[mm]
Adapter/
Remark



Energy-saving pumps*)

Infinitely variable, 1 ~ 230V,
50Hz
 $T_{max} = 95^{\circ}C$ or $110^{\circ}C$

Type

Motor
Overall length
[mm]
Adapter/
Remark



Standard pumps*)

1-/3-/4-stages
1 ~ 230V or 3 ~ 400V, 50Hz
 $T_{max} = 110^{\circ}C$ or $130^{\circ}C / 140^{\circ}C$

Type

Motor
Overall length
[mm]
Adapter/
Remark

Rp 1 (Pump thread G 1½)

PN	Motor	Overall length [mm]	Type	Motor	Overall length [mm]	Adapter/Remark	Type	Motor	Overall length [mm]	Adapter/Remark	Type	Motor	Overall length [mm]	Adapter/Remark
C 22/50 Rio	10	1 180	Stratos ECO 25/1-5	1 180	-		Star-E 25/1-5	1 180	-		Star-RS 25/6	1 180	-	
C 22/60 Rio	10	1 180	Stratos ECO 25/1-5	1 180	-		Star-E 25/1-5	1 180	-		Star-RS 25/6	1 180	-	
C 22/60-130 Rio	10	1 130	Stratos ECO 25/1-5-130	1 130	-		Star-E 25/1-5-130	1 130	-		Star-RS 25/6-130	1 130	-	
C 25-15 Rio	10	1 180	Stratos ECO 25/1-3	1 180	-		Star-E 25/1-3	1 180	-		Star-RS 25/2	1 180	-	
C 25-25 Rio	10	1 180	Stratos ECO 25/1-3	1 180	-		Star-E 25/1-3	1 180	-		Star-RS 25/2	1 180	-	
C 25-40 130 Rio	10	1 130	Stratos ECO 25/1-5-130	1 130	-		Star-E 25/1-3-130	1 130	-		Star-RS 25/4-130	1 130	-	
C 25-40 Rio	10	1 180	Stratos ECO 25/1-3	1 180	-		Star-E 25/1-3	1 180	-		Star-RS 25/4	1 180	-	
C 25-50 Rio	10	1 180	Stratos ECO 25/1-3	1 180	-		Star-E 25/1-3	1 180	-		Star-RS 25/4	1 180	-	
C 25-50-130 Rio	10	1 130	Stratos ECO 25/1-5-130	1 130	-		Star-E 25/1-3-130	1 130	-		Star-RS 25/4-130	1 130	-	
C 25-60 Rio	10	1 180	Stratos ECO 25/1-5	1 180	-		Star-E 25/1-5	1 180	-		Star-RS 25/6	1 180	-	
C 25-60 130 Rio	10	1 130	Stratos ECO 25/1-5-130	1 130	-		Star-E 25/1-5-130	1 130	-		Star-RS 25/6-130	1 130	-	
E 25/1-5 Riotron	10	1 180	Stratos ECO 25/1-5	1 180	-		Star-E 25/1-5	1 180	-		-	-	-	
S 25-40 Riotronic	10	1 180	Stratos ECO 25/1-3	1 180	-		Star-E 25/1-3	1 180	-		-	-	-	
S 25-60 Riotronic	10	1 180	Stratos ECO 25/1-5	1 180	-		Star-E 25/1-5	1 180	-		-	-	-	

Rp 1¼ (Pump thread G 2)

30-10 E/D Rio	10	1/3 180	Stratos 30/1-12	1 180	-		TOP-E 30/1-10	1 180	-		TOP-S 30/10	1/3 180	-
30-100 E/D Rio	10	1/3 180	Stratos 30/1-12	1 180	-		TOP-E 30/1-10	1 180	-		TOP-S 30/10	1/3 180	-
30-100 Riotec	10	1 180	Stratos 30/1-12	1 180	-		TOP-E 30/1-10	1 180	-		-	-	-
30-120 Rio-Eco	10	1 180	Stratos 30/1-12	1 180	-		-	-	-		-	-	-
30-40 Riotronic	10	1 180	Stratos ECO 30/1-3	1 180	-		Star-E 30/1-3	1 180	-		-	-	-
30-60 Rio-Eco	10	1 180	Stratos 30/1-6	1 180	-		-	-	-		-	-	-
30-60 Riotronic	10	1 180	Stratos ECO 30/1-5	1 180	-		Star-E 30/1-5	1 180	-		-	-	-
30-60 Riotronic SSM	10	1 180	Stratos ECO 30/1-5 BMS	1 180	-		-	-	-		-	-	-
30-7 E/D Rio	10	1/3 180	Stratos 30/1-8	1 180	-		TOP-E 30/1-7	1 180	-		TOP-S 30/7	1/3 180	-
30-70 E/D Rio	10	1/3 180	Stratos 30/1-8	1 180	-		TOP-E 30/1-7	1 180	-		TOP-S 30/7	1/3 180	-
30-70 Riotec	10	1 180	Stratos 30/1-8	1 180	-		TOP-E 30/1-7	1 180	-		-	-	-
30-80 Rio-Eco	10	1 180	Stratos 30/1-8	1 180	-		-	-	-		-	-	-
31-4 E Riovar	10	1 180	Stratos ECO 30/1-5	1 180	-		Star-E 30/1-5	1 180	-		Star-RS 30/4	1 180	-
32-1 E Riovar	10	1 180	Stratos ECO 30/1-3	1 180	-		Star-E 30/1-3	1 180	-		Star-RS 30/4	1 180	-
32-12 E/D Riovar	10	1/3 180	Stratos 30/1-8	1 180	-		TOP-E 30/1-7	1 180	-		TOP-S 30/7	1/3 180	-
32-15 E/D Riovar	10	1/3 180	Stratos 30/1-8	1 180	-		TOP-E 30/1-7	1 180	-		TOP-S 30/7	1/3 180	-
32-17 E/D Riovar	10	1/3 180	Stratos 30/1-12	1 180	-		TOP-E 30/1-10	1 180	-		TOP-S 30/10	1/3 180	-
32-2 E Riovar	10	1 180	Stratos ECO 30/1-3	1 180	-		Star-E 30/1-3	1 180	-		Star-RS 30/4	1 180	-
32-3 E Riovar	10	1 180	Stratos ECO 30/1-3	1 180	-		Star-E 30/1-3	1 180	-		Star-RS 30/4	1 180	-
32-4 E Riovar	10	1 180	Stratos ECO 30/1-5	1 180	-		Star-E 30/1-5	1 180	-		Star-RS 30/6	1 180	-
32-5 E Riovar	10	1 180	Stratos ECO 30/1-5	1 180	-		Star-E 30/1-5	1 180	-		Star-RS 30/6	1 180	-
32-6 E/D Riovar	10	1/3 180	Stratos 30/1-6	1 180	-		TOP-E 30/1-7	1 180	-		TOP-S 30/7	1/3 180	-
32-7 E/D Riovar	10	1/3 180	Stratos 30/1-8	1 180	-		TOP-E 30/1-7	1 180	-		TOP-S 30/7	1/3 180	-
34-2 E/D Riovar	10	1 180	Stratos ECO 30/1-5	1 180	-		Star-E 30/1-5	1 180	-		Star-RS 30/4	1 180	-
34-2 E/D Riovar	10	3 180	-	-	-		-	-	-		RP 30/80 r	1/3 180	-
34-8 E/D Riovar	10	1/3 180	Stratos 30/1-6	1 180	-		TOP-E 30/1-7	1 180	-		TOP-S 30/7	1/3 180	-
A 3 V	10	1/3 180	Stratos 30/1-8	1 180	-		TOP-E 30/1-7	1 180	-		TOP-S 30/7	1/3 180	-

*) Energy efficiency class for each type see page 3-5

■ = Replacement pumps in accordance with EnEV (German Energy Saving Ordinance)

Observe current type (three-phase/single-phase) and nominal pressure of pump (PN 6/PN 10)! — 1 = 1 ~ 230 V single-phase, 3 = 3 ~ 400 V three-phase

Check separately whether existing switchgears can be used.

KSB				Wilo – new											
Single-head pumps				High-efficiency pumps				Energy-saving pumps*)				Standard pumps*)			
				Infinitely variable, 1~ 230V, 50Hz Stratos T _{min} : -10°C/T _{max} : 110°C Stratos ECO T _{min} : +15°C/T _{max} : 110°C				Infinitely variable, 1~ 230V, 50Hz T _{max} = 95°C or 110°C				1-3-/4-stages 1~ 230V or 3~ 400V, 50Hz T _{max} = 110°C or 130°C/140°C			
DN Type	PN	Motor	Overall length [mm]	Type	Motor	Overall length [mm]	Adapter/Remark	Type	Motor	Overall length [mm]	Adapter/Remark	Type	Motor	Overall length [mm]	Adapter/Remark

Rp 1¼ (Pump thread G 2)

B 3 V	10	3	180	–	–	–	–	–	–	–	–	RP 30/100 r	1/3	180	–
B 3 V	10	1	180	Stratos ECO 30/1-5	1	180	–	Star-E 30/1-5	1	180	–	Star-RS 30/6	1	180	–
C 3 V	10	1	180	Stratos ECO 30/1-5	1	180	–	Star-E 30/1-5	1	180	–	Star-RS 30/4	1	180	–
C 30-25 Rio	10	1	180	Stratos ECO 30/1-3	1	180	–	Star-E 30/1-3	1	180	–	Star-RS 30/2	1	180	–
C 30-40 Rio	10	1	180	Stratos ECO 30/1-3	1	180	–	Star-E 30/1-3	1	180	–	Star-RS 30/4	1	180	–
C 30-60 Rio	10	1	180	Stratos ECO 30/1-5	1	180	–	Star-E 30/1-5	1	180	–	Star-RS 30/6	1	180	–
C 32/20 Riomatic	10	1	180	Stratos ECO 30/1-3	1	180	–	Star-E 30/1-3	1	180	–	–	–	–	–
C 32/25 Rio	10	1	180	Stratos ECO 30/1-3	1	180	–	Star-E 30/1-3	1	180	–	Star-RS 30/2	1	180	–
C 32/35 Riomatic	10	1	180	Stratos ECO 30/1-5	1	180	–	Star-E 30/1-5	1	180	–	–	–	–	–
C 32/40 Rio	10	1	180	Stratos ECO 30/1-3	1	180	–	Star-E 30/1-3	1	180	–	Star-RS 30/4	1	180	–
C 32/50 Rio	10	1	180	Stratos ECO 30/1-5	1	180	–	Star-E 30/1-5	1	180	–	Star-RS 30/6	1	180	–
C 32/60 Rio	10	1	180	Stratos ECO 30/1-5	1	180	–	Star-E 30/1-5	1	180	–	Star-RS 30/6	1	180	–
D 30 D	10	3	206	–	–	–	–	–	–	–	–	TOP-D 30	1/3	180	R9
E 30/1-5 Riotron	10	1	180	Stratos ECO 30/1-5	1	180	–	Star-E 30/1-5	1	180	–	–	–	–	–
F 3 V	10	1	180	Stratos ECO 30/1-3	1	180	–	Star-E 30/1-3	1	180	–	Star-RS 30/4	1	180	–
S 30-40 Riomatic	10	1	180	Stratos ECO 30/1-3	1	180	–	Star-E 30/1-3	1	180	–	–	–	–	–
S 30-60 Riomatic	10	1	180	Stratos ECO 30/1-5	1	180	–	Star-E 30/1-5	1	180	–	–	–	–	–

DN 32

32-120 Rio-Eco	6/10	1	220	Stratos 32/1-12	1	220	–	–	–	–	–	–	–	–	–
----------------	------	---	-----	-----------------	---	-----	---	---	---	---	---	---	---	---	---

DN 40

40-1/10 Riomatic	6/10	1	250	Stratos 40/1-12	1	250	–	TOP-E 40/1-10	1	250	–	–	–	–	–
40-10 D Rio	6/10	3	250	Stratos 40/1-12	1	250	–	TOP-E 40/1-10	1	250	–	TOP-S 40/10	3	250	–
40-100 D Rio	6/10	3	250	Stratos 40/1-12	1	250	–	TOP-E 40/1-10	1	250	–	TOP-S 40/10	3	250	–
40-100 Riomatic	6/10	1	250	Stratos 40/1-12	1	250	–	TOP-E 40/1-10	1	250	–	–	–	–	–
40-120 Rio-Eco	6/10	1	250	Stratos 40/1-12	1	250	–	–	–	–	–	–	–	–	–
40-4 E/D Rio	6/10	1/3	220	Stratos 40/1-4	1	220	–	TOP-E 40/1-4	1	220	–	TOP-S 40/4	1/3	220	–
40-40 E/D Rio	6/10	1/3	220	Stratos 40/1-4	1	220	–	TOP-E 40/1-4	1	220	–	TOP-S 40/4	1/3	220	–
40-40 Rio-Eco	6/10	1	220	Stratos 40/1-4	1	220	–	–	–	–	–	–	–	–	–
40-40 Riomatic	6/10	1	220	Stratos 40/1-4	1	220	–	TOP-E 40/1-4	1	220	–	–	–	–	–
40-7 E/D Rio	6/10	1/3	250	Stratos 40/1-8	1	220	F1	TOP-E 40/1-10	1	250	–	TOP-S 40/7	1/3	250	–
40-70 E/D Rio	6/10	1/3	250	Stratos 40/1-8	1	220	F1	TOP-E 40/1-10	1	250	–	TOP-S 40/7	1/3	250	–
40-80 Rio-Eco	6/10	1	220	Stratos 40/1-8	1	220	–	–	–	–	–	–	–	–	–
42-12 E/D Riovar	6/10	1/3	250	Stratos 40/1-8	1	220	F1	TOP-E 40/1-10	1	250	–	TOP-S 40/7	1/3	250	–
42-17 E/D Riovar	6/10	1/3	250	Stratos 40/1-8	1	220	F1	TOP-E 40/1-10	1	250	–	TOP-S 40/7	1/3	250	–
42-25 E/D Riovar	6/10	1/3	250	Stratos 40/1-8	1	220	F1	TOP-E 40/1-10	1	250	–	TOP-S 40/10	3	250	–
42-6 E/D Riovar	6/10	1/3	250	Stratos 40/1-4	1	220	F1	TOP-E 40/1-4	1	220	F1	TOP-S 40/4	1/3	220	F1
42-7 E/D Riovar	6/10	1/3	220	Stratos 40/1-4	1	220	–	TOP-E 40/1-4	1	220	–	TOP-S 40/4	1/3	220	–
44-18 D Riovar	6/10	3	320	Stratos 40/1-8	1	220	2xF26	TOP-E 40/1-10	1	250	F0+F26+Di	P 40/160 r	3	320	–
44-30 D Riovar	6/10	3	320	Stratos 40/1-8	1	220	2xF26	TOP-E 40/1-10	1	250	F0+F26+Di	P 40/160 r	3	320	–
44-8 E/D Riovar	6/10	1/3	250	Stratos 40/1-4	1	220	F1	TOP-E 40/1-4	1	220	F1	TOP-S 40/4	1/3	220	F1
A 4 V	6/10	1/3	250	Stratos 40/1-4	1	220	F1	TOP-E 40/1-4	1	220	F1	TOP-S 40/4	1/3	220	F1
C 4 V	6/10	1	200	Stratos 40/1-4	1	220	Mod. pipe	TOP-E 40/1-4	1	220	Mod. pipe	RP 30/100 r	1/3	180	2xRF12(PN6)

*) Energy efficiency class for each type see page 3–5

■ = Replacement pumps in accordance with EnEV (German Energy Saving Ordinance)

Observe current type (three-phase/single-phase) and nominal pressure of pump (PN 6/PN 10)! — 1 = 1~ 230 V single-phase, 3 = 3~ 400 V three-phase

Check separately whether existing switchgears can be used.

Wilo Replacement Guide Heating

KSB

Single-head pumps



DN
Type

PN
Motor
Overall length
[mm]

Wilo – new



High-efficiency pumps

Infinitely variable, 1~230V, 50Hz
Stratos $T_{min} = -10^{\circ}C / T_{max} = 110^{\circ}C$
Stratos ECO $T_{min} = +15^{\circ}C / T_{max} = 110^{\circ}C$

Type

Motor
Overall length
[mm]
Adapter/
Remark



Energy-saving pumps*)

Infinitely variable, 1~230V,
50Hz
 $T_{max} = 95^{\circ}C$ or $110^{\circ}C$

Type

Motor
Overall length
[mm]
Adapter/
Remark



Standard pumps*)

1-/3-/4-stages
1~230V or 3~400V, 50Hz
 $T_{max} = 110^{\circ}C$ or $130^{\circ}C / 140^{\circ}C$

Type

Motor
Overall length
[mm]
Adapter/
Remark

DN 40

DN	PN	Motor	Overall length [mm]	Type	Motor	Overall length [mm]	Adapter/Remark	Type	Motor	Overall length [mm]	Adapter/Remark	Type	Motor	Overall length [mm]	Adapter/Remark
D 40 D	6/10	3	220	-	-	-	-	Star-E 25/1-5	1	180	2 x RF9(PN6)	TOP-D 40	1/3	220	-
E 40/1-5 Riotron	6/10	1	220	Stratos 40/1-4	1	220	-	TOP-E 40/1-4	1	220	-	-	-	-	-
K 48	6/10	1/3	250	Stratos 40/1-4	1	220	F1	TOP-E 40/1-4	1	220	F1	TOP-S 40/4	1/3	220	F1
L 4	6/10	1/3	250	Stratos 40/1-8	1	220	F1	TOP-E 40/1-10	1	250	-	TOP-S 40/7	1/3	250	-
M 4	6/10	1/3	250	Stratos 40/1-12	1	250	-	TOP-E 40/1-10	1	250	-	TOP-S 40/10	3	250	-

DN 50

50-1/10 Riotec	6/10	1	280	Stratos 50/1-12	1	280	-	TOP-E 50/1-10	1	280	-	-	-	-	-
50-1/7 Riotec	6/10	1	280	Stratos 50/1-9	1	280	-	TOP-E 50/1-7	1	280	-	-	-	-	-
50-10 D Rio	6/10	3	280	Stratos 50/1-12	1	280	-	TOP-E 50/1-10	1	280	-	TOP-S 50/10	3	280	-
50-100 D Rio	6/10	3	280	Stratos 50/1-12	1	280	-	TOP-E 50/1-10	1	280	-	TOP-S 50/10	3	280	-
50-100 Riotec	6/10	1	280	Stratos 50/1-12	1	280	-	TOP-E 50/1-10	1	280	-	-	-	-	-
50-120 Rio-Eco	6/10	1	280	Stratos 50/1-12	1	280	-	-	-	-	-	-	-	-	-
50-4 E/D Rio	6/10	1/3	240	Stratos 50/1-9	1	280	Mod. pipe	TOP-E 50/1-6	1	240	-	TOP-S 50/4	1/3	240	-
50-40 E/D Rio	6/10	1/3	240	Stratos 50/1-9	1	280	Mod. pipe	TOP-E 50/1-6	1	240	-	TOP-S 50/4	1/3	240	-
50-60 Riotec	6/10	1	240	Stratos 50/1-8	1	240	-	TOP-E 50/1-6	1	240	-	-	-	-	-
50-7 D Rio	6/10	3	280	Stratos 50/1-9	1	280	-	TOP-E 50/1-7	1	280	-	TOP-S 50/7	3	280	-
50-70 D Rio	6/10	3	280	Stratos 50/1-9	1	280	-	TOP-E 50/1-7	1	280	-	TOP-S 50/7	3	280	-
50-70 Riotec	6/10	1	280	Stratos 50/1-9	1	280	-	TOP-E 50/1-7	1	280	-	-	-	-	-
50-80 Rio-Eco	6/10	1	240	Stratos 50/1-8	1	240	-	-	-	-	-	-	-	-	-
50-90 Rio-Eco	6/10	1	280	Stratos 50/1-9	1	280	-	-	-	-	-	-	-	-	-
52-12 E/D Riovar	6/10	1/3	280	Stratos 50/1-8	1	240	2 x F3	TOP-E 50/1-6	1	240	2 x F3	TOP-S 50/4	1/3	240	2 x F3
52-15 E/D Riovar	6/10	1/3	240	Stratos 50/1-8	1	240	-	TOP-E 50/1-6	1	240	-	TOP-S 50/4	1/3	240	2 x F3
52-17 E/D Riovar	6/10	1/3	240	Stratos 50/1-8	1	240	-	TOP-E 50/1-6	1	240	-	TOP-S 50/4	1/3	240	2 x F3
52-25 E/D Riovar	6/10	1/3	280	Stratos 50/1-8	1	240	2 x F3	TOP-E 50/1-6	1	240	2 x F3	TOP-S 50/4	1/3	240	2 x F3
52-32 D Riovar	6/10	3	280	Stratos 50/1-9	1	280	-	TOP-E 50/1-7	1	280	-	TOP-S 50/7	3	280	-
52-40 D Riovar	6/10	3	280	Stratos 50/1-9	1	280	-	TOP-E 50/1-7	1	280	-	TOP-S 50/7	3	280	-
52-45 D Riovar	6/10	3	280	Stratos 50/1-12	1	280	-	TOP-E 50/1-10	1	280	-	TOP-S 50/10	3	280	-
52-85 D Riovar	6/10	3	340	Stratos 50/1-12	1	280	2 x F4	TOP-E 50/1-10	1	280	2 x F4	TOP-S 50/15	3	340	-
54-100 D Riovar	10	3	440	-	-	-	-	IP-E 50/115-0,75/2	3	280	Mod. pipe	P 50/250 r	3	440	-
54-150 D Riovar	10	3	460	-	-	-	-	IP-E 50/115-0,75/2	3	280	Mod. pipe	P 50/250 r	3	440	F3
54-18 D Riovar	6/10	3	280	Stratos 50/1-8	1	240	2 x F3	TOP-E 50/1-6	1	240	2 x F3	TOP-S 50/4	1/3	240	2 x F3
54-30 D Riovar	6/10	3	340	Stratos 50/1-9	1	280	2 x F4	TOP-E 50/1-7	1	280	2 x F4	TOP-S 50/7	3	280	2 x F4
54-48 D Riovar	6/10	3	340	Stratos 50/1-9	1	280	2 x F4	TOP-E 50/1-7	1	280	2 x F4	P 50/160 r	3	340	-
D 50 D	6/10	3	240	-	-	-	-	-	-	-	-	TOP-D 50	1/3	240	-
E 50/1-7 Riotron	6	1	240	Stratos 50/1-8	1	240	-	TOP-E 50/1-6	1	240	-	-	-	-	-
K 56	6	1/3	280	Stratos 50/1-8	1	240	2 x F3	TOP-E 50/1-6	1	240	2 x F3	TOP-S 50/4	1/3	240	2 x F3
K 57	6	1/3	280	Stratos 50/1-8	1	240	2 x F3	TOP-E 50/1-6	1	240	2 x F3	TOP-S 50/4	1/3	240	2 x F3
K 58	6	1/3	280	Stratos 50/1-8	1	240	2 x F3	TOP-E 50/1-6	1	240	2 x F3	TOP-S 50/4	1/3	240	-
K 59	6	1/3	280	Stratos 50/1-8	1	240	2 x F3	TOP-E 50/1-6	1	240	2 x F3	TOP-S 50/4	1/3	240	-
L 5	6/10	1/3	280	Stratos 50/1-9	1	280	-	TOP-E 50/1-7	1	280	-	TOP-S 50/4	1/3	240	2 x F3
L 51	6/10	1/3	280	Stratos 50/1-8	1	240	2 x F3	TOP-E 50/1-6	1	240	2 x F3	TOP-S 50/4	1/3	240	2 x F3
L 58	6	1/3	280	Stratos 50/1-9	1	280	-	TOP-E 50/1-7	1	280	-	TOP-S 50/4	1/3	240	2 x F3

*) Energy efficiency class for each type see page 3-5

■ = Replacement pumps in accordance with EnEV (German Energy Saving Ordinance)

Observe current type (three-phase/single-phase) and nominal pressure of pump (PN 6/PN 10)! — 1 = 1~230 V single-phase, 3 = 3~400 V three-phase

Check separately whether existing switchgears can be used.

KSB			Wilo – new								
Single-head pumps			High-efficiency pumps Infinitely variable, 1~ 230V, 50Hz Stratos T _{min} : -10°C/T _{max} : 110°C Stratos ECO T _{min} : +15°C/T _{max} : 110°C			Energy-saving pumps*) Infinitely variable, 1~ 230V, 50Hz T _{max} = 95°C or 110°C			Standard pumps*) 1-3-/4-stages 1~ 230V or 3~ 400V, 50Hz T _{max} = 110°C or 130°C/140°C		
DN Type	PN	Motor Overall length [mm]	Type	Motor Overall length [mm]	Adapter/Remark	Type	Motor Overall length [mm]	Adapter/Remark	Type	Motor Overall length [mm]	Adapter/Remark
DN 50											
L 59	6 1/3	280	Stratos 50/1-9	1 280	-	TOP-E 50/1-7	1 280	-	TOP-S 50/4	1/3 240	2x F3
M 5	6/10	3 280	Stratos 50/1-12	1 280	-	TOP-E 50/1-10	1 280	-	TOP-S 50/7	3 280	-
DN 65											
62-130 D Riovar	6/10	3 340	-	-	-	IP-E 65/115-1,5/2	3 340	-	TOP-S 65/15	3 340	-
62-32 D Riovar	6/10	3 280	Stratos 65/1-9	1 280	-	TOP-E 65/1-10	1 340	Mod. pipe	TOP-S 65/7	3 280	-
62-40 D Riovar	6/10	3 340	Stratos 65/1-9	1 280	2x F11	TOP-E 65/1-10	1 340	-	TOP-S 65/7	3 280	2x F11
62-60 D Riovar	6/10	3 340	Stratos 65/1-9	1 280	2x F11	TOP-E 65/1-10	1 340	-	TOP-S 65/10	3 340	-
62-65 D Riovar	6/10	3 340	Stratos 65/1-9	1 280	2x F11	TOP-E 65/1-10	1 340	-	TOP-S 65/10	3 340	-
62-70 D Riovar	6/10	3 340	-	-	-	IP-E 65/115-1,5/2	3 340	-	TOP-S 65/13	3 340	-
64-160 D Riovar	10	3 475	-	-	-	IP-E 65/115-1,5/2	3 340	Mod. pipe	P 65/250 r	3 475	-
64-250 D Riovar	10	3 500	-	-	-	IP-E 65/115-1,5/2	3 340	Mod. pipe	TOP-S 65/13	3 340	Mod. pipe
64-30 D Riovar	6/10	3 340	Stratos 65/1-9	1 280	2x F11	TOP-E 65/1-10	1 340	-	P 65/125 r	3 340	-
64-48 D Riovar	6/10	3 340	Stratos 65/1-9	1 280	2x F11	TOP-E 65/1-10	1 340	-	TOP-S 65/10	3 340	2x F11
64-75 D Riovar	6/10	3 340	Stratos 65/1-9	1 280	2x F11	TOP-E 65/1-10	1 340	-	TOP-S 65/10	3 340	2x F11
65-1/10 Riotec	6/10	1 340	Stratos 65/1-9	1 280	2x F11	TOP-E 65/1-10	1 340	-	-	-	-
65-10 D Rio	6/10	3 340	Stratos 65/1-9	1 280	2x F11	TOP-E 65/1-10	1 340	-	TOP-S 65/10	3 340	-
65-100 D Rio	6/10	3 340	Stratos 65/1-9	1 280	2x F11	TOP-E 65/1-10	1 340	-	TOP-S 65/10	3 340	-
65-100 Riotec	6/10	1 340	Stratos 65/1-9	1 280	2x F11	TOP-E 65/1-10	1 340	-	-	-	-
65-120 Rio-Eco	6/10	1 340	Stratos 65/1-12	1 340	-	-	-	-	-	-	-
65-13 D Rio	6/10	3 340	-	-	-	IP-E 65/115-1,5/2	3 340	-	TOP-S 65/13	3 340	-
65-130 D Rio	6/10	3 340	-	-	-	IP-E 65/115-1,5/2	3 340	-	TOP-S 65/13	3 340	-
65-7 D Rio	6/10	3 280	Stratos 65/1-9	1 280	-	TOP-E 65/1-10	1 340	Mod. pipe	TOP-S 65/7	3 280	-
65-70 D Rio	6/10	3 280	Stratos 65/1-9	1 280	-	TOP-E 65/1-10	1 340	Mod. pipe	TOP-S 65/7	3 280	-
65-90 Rio-Eco	6/10	1 280	Stratos 65/1-9	1 280	-	-	-	-	-	-	-
D 65 D	6/10	3 280	-	-	-	-	-	-	TOP-D 65	1/3 280	-
G 67	6 1/3	280	-	-	-	-	-	-	-	-	-
G 69	6 1/3	280	-	-	-	-	-	-	-	-	-
L 66	6 1/3	340	Stratos 65/1-9	1 280	2x F11	TOP-E 65/1-10	1 340	-	TOP-S 65/7	3 280	2x F11
L 67	6 1/3	340	Stratos 65/1-9	1 280	2x F11	TOP-E 65/1-10	1 340	-	TOP-S 65/7	3 280	-
L 68	6 1/3	340	Stratos 65/1-9	1 280	2x F11	TOP-E 65/1-10	1 340	-	TOP-S 65/7	3 280	-
L 69	6 1/3	340	Stratos 65/1-9	1 280	2x F11	TOP-E 65/1-10	1 340	-	TOP-S 65/7	3 280	2x F11
M 6	6/10	3 340	Stratos 65/1-9	1 280	2x F11	TOP-E 65/1-10	1 340	-	TOP-S 65/10	3 340	-
M 61	6/10	3 340	Stratos 65/1-9	1 280	2x F11	TOP-E 65/1-10	1 340	-	TOP-S 65/7	3 280	2x F11
R 6	6/10	3 340	-	-	-	IP-E 65/115-1,5/2	3 340	-	TOP-S 65/13	3 340	-
DN 80											
80-1/10 Riotec	6/10	1 360	Stratos 80/1-12	1 360	-	TOP-E 80/1-10	1 360	-	-	-	-
80-10 D Rio	6/10	3 360	Stratos 80/1-12	1 360	-	TOP-E 80/1-10	1 360	-	TOP-S 80/10	3 360	-
80-100 D Rio	6/10	3 360	Stratos 80/1-12	1 360	-	TOP-E 80/1-10	1 360	-	TOP-S 80/10	3 360	-
80-100 Riotec	6/10	1 360	Stratos 80/1-12	1 360	-	TOP-E 80/1-10	1 360	-	-	-	-
80-120 Rio-Eco	6/10	1 360	Stratos 80/1-12	1 360	-	-	-	-	-	-	-
80-7 D Rio	6/10	3 360	Stratos 80/1-12	1 360	-	TOP-E 80/1-10	1 360	-	TOP-S 80/7	3 360	-
DN 80											

*) Energy efficiency class for each type see page 3-5

= Replacement pumps in accordance with EnEV (German Energy Saving Ordinance)

Observe current type (three-phase/single-phase) and nominal pressure of pump (PN 6/PN 10)! — 1 = 1~ 230 V single-phase, 3 = 3~ 400 V three-phase

Check separately whether existing switchgears can be used.

Wilo Replacement Guide Heating

KSB

Wilo – new

Single-head pumps



High-efficiency pumps
 Infinitely variable, 1 ~ 230V, 50Hz
 Stratos $T_{min}: -10^{\circ}C/T_{max}: 110^{\circ}C$
 Stratos ECO $T_{min}: +15^{\circ}C/T_{max}: 110^{\circ}C$

Energy-saving pumps*)
 Infinitely variable, 1 ~ 230V,
 50Hz
 $T_{max} = 95^{\circ}C$ or $110^{\circ}C$

Standard pumps*)
 1-/3-/4-stages
 1 ~ 230V or 3 ~ 400V, 50Hz
 $T_{max} = 110^{\circ}C$ or $130^{\circ}C/140^{\circ}C$

DN Type	PN	Motor	Overall length [mm]	Type			Type			Type		
				Motor	Overall length [mm]	Adapter/ Remark	Motor	Overall length [mm]	Adapter/ Remark	Motor	Overall length [mm]	Adapter/ Remark
80-70 D Rio	6/10	3	360	Stratos 80/1-12	1 360	-	TOP-E 80/1-10	1 360	-	TOP-S 80/7	3 360	-
82-100 D Riovar	6/10	3	360	Stratos 80/1-12	1 360	-	TOP-E 80/1-10	1 360	-	TOP-S 80/10	3 360	-
82-130 D Riovar	6/10	3	360	Stratos 80/1-12	1 360	-	TOP-E 80/1-10	1 360	-	TOP-S 80/10	3 360	-
82-60 D Riovar	6/10	3	360	Stratos 80/1-12	1 360	-	TOP-E 80/1-10	1 360	-	TOP-S 80/10	3 360	-
82-65 D Riovar	6/10	3	360	Stratos 80/1-12	1 360	-	TOP-E 80/1-10	1 360	-	TOP-S 80/10	3 360	-
82-85 D Riovar	6/10	3	360	Stratos 80/1-12	1 360	-	TOP-E 80/1-10	1 360	-	TOP-S 80/10	3 360	-
84-250 D Riovar	10	3	500	-	-	-	IP-E 80/115-2,2/2	3 360	Mod. pipe	P 80/250 r	3 500	-
84-48 D Riovar	6/10	3	360	Stratos 80/1-12	1 360	-	TOP-E 80/1-10	1 360	-	TOP-S 80/7	3 360	-
84-75 D Riovar	6/10	3	360	Stratos 80/1-12	1 360	-	TOP-E 80/1-10	1 360	-	TOP-S 80/10	3 360	-
D 80 D	6/10	3	330	-	-	-	-	-	-	TOP-D 80	1/3 330	-
K 86	6 1/3	330	-	-	-	-	-	-	-	TOP-D 80	1/3 330	-
K 87	6	330	-	-	-	-	-	-	-	TOP-D 80	1/3 330	-
K 88	6 1/3	330	-	-	-	-	-	-	-	TOP-D 80	1/3 330	-
K 89	6	330	-	-	-	-	-	-	-	TOP-D 80	1/3 330	-
M 8	6	360	Stratos 80/1-12	1 360	-	TOP-E 80/1-10	1 360	-	TOP-S 80/7	3 360	-	
M 86	6	400	Stratos 80/1-12	1 360	F18(PN6)	TOP-E 80/1-10	1 360	F18(PN6)	TOP-S 80/7	3 360	F18(PN6)	
M 87	6	400	Stratos 80/1-12	1 360	F18(PN6)	TOP-E 80/1-10	1 360	F18(PN6)	TOP-S 80/7	3 360	F18(PN6)	
M 88	6	400	Stratos 80/1-12	1 360	F18(PN6)	TOP-E 80/1-10	1 360	F18(PN6)	TOP-S 80/7	3 360	F18(PN6)	
M 89	6	400	Stratos 80/1-12	1 360	F18(PN6)	TOP-E 80/1-10	1 360	F18(PN6)	TOP-S 80/7	3 360	F18(PN6)	
R 8	6/10	360	Stratos 80/1-12	1 360	-	TOP-E 80/1-10	1 360	-	TOP-S 80/10	3 360	-	
S 8	6/10	360	-	-	-	IP-E 80/115-2,2/2	3 360	-	TOP-S 80/10	3 360	-	

DN 100

100-100 D Rio	6/10	3 360	Stratos 100/1-12	1 360	-	TOP-E 100/1-10	1 360	-	TOP-S 100/10	3 360	-
100-100 Riotec	6/10	1 360	Stratos 100/1-12	1 360	-	TOP-E 100/1-10	1 360	-	-	-	-
100-120 Rio-Eco	6/10	1 360	Stratos 100/1-12	1 360	-	-	-	-	-	-	-
102-130 D Riovar	6/10	3 395	Stratos 100/1-12	1 360	F34(PN6)	TOP-E 100/1-10	1 360	F34(PN6)	TOP-S 100/10	3 360	F34(PN6)
104-110 D Riovar	6/10	3 395	Stratos 100/1-12	1 360	F34(PN6)	TOP-E 100/1-10	1 360	F34(PN6)	P 100/160 r	3 395	-
104-250 D Riovar	10	3 550	-	-	-	IP-E 80/115-2,2/2	3 360	Mod. pipe	P 100/200 r	3 550	-
104-250 D Riovar	10	3 500	-	-	-	IP-E 80/115-2,2/2	3 360	Mod. pipe	P 100/200 r	3 550	Mod. pipe
D 100 D	6/10	3 380	-	-	-	-	-	-	TOP-D 100	1/3 380	-
M 108	6	450	-	-	-	IP-E 80/115-2,2/2	3 360	Mod. pipe	P 100/160 r	3 395	F35(PN6)
M 109	6	450	-	-	-	IP-E 80/115-2,2/2	3 360	Mod. pipe	P 100/160 r	3 395	F35(PN6)
R 10	6/10	3 450	-	-	-	IP-E 80/115-2,2/2	3 360	Mod. pipe	P 100/160 r	3 395	F35(PN6)
R 101	6/10	3 450	Stratos 100/1-12	1 360	(F34+F35) (PN6)	TOP-E 100/1-10	1 360	(F34+F35) (PN6)	P 100/160 r	3 395	F35(PN6)
S 10	6/10	3 450	-	-	-	IP-E 80/115-2,2/2	3 360	Mod. pipe	P 100/200 r	3 550	Mod. pipe

DN 125

D 125 D	6/10	3 450	-	-	-	-	-	-	TOP-D 125	3 450	-
---------	------	-------	---	---	---	---	---	---	-----------	-------	---

*) Energy efficiency class for each type see page 3-5

■ = Replacement pumps in accordance with EnEV (German Energy Saving Ordinance)

Observe current type (three-phase/single-phase) and nominal pressure of pump (PN 6/PN 10)! — 1 = 1 ~ 230 V single-phase, 3 = 3 ~ 400 V three-phase

Check separately whether existing switchgears can be used.

KSB			Wilo – new								
Twin-head pumps 			High-efficiency pumps Infinitely variable, 1~ 230V, 50Hz Stratos $T_{min}: -10^{\circ}C/T_{max}: 110^{\circ}C$ Stratos ECO $T_{min}: +15^{\circ}C/T_{max}: 110^{\circ}C$			Energy-saving pumps*) Infinitely variable, 1~ 230V, 50Hz $T_{max} = 95^{\circ}C$ or $110^{\circ}C$			Standard pumps*) 1-/3-/4-stages 1~ 230V or 3~ 400V, 50Hz $T_{max} = 110^{\circ}C$ or $130^{\circ}C/140^{\circ}C$		
DN Type	PN	Motor Overall length [mm]	Type	Motor Overall length [mm]	Adapter/Remark	Type	Motor Overall length [mm]	Adapter/Remark	Type	Motor Overall length [mm]	Adapter/Remark

Rp 1 1/4 (Pump thread G 2)

A 3 VZ E/D	10	1/3	180	Stratos-D 32/1-8	1 220	Mod. pipe	TOP-ED 32/1-7	1 220	Mod. pipe	Star-RSD 30/6	1 180	-
B 3 VZ E/D	10	1/3	180	Stratos-D 32/1-8	1 220	Mod. pipe	TOP-ED 32/1-7	1 220	Mod. pipe	Star-RSD 30/6	1 180	F1
Z 31-4 E Riovar	10	1	180	Stratos-D 32/1-8	1 220	Mod. pipe	TOP-ED 32/1-7	1 220	Mod. pipe	Star-RSD 30/6	1 180	-
Z 32-2 E Riovar	10	1	180	-	-	-	-	-	-	Star-RSD 30/4	1 180	-
Z 32-3 E Riovar	10	1	180	-	-	-	-	-	-	Star-RSD 30/4	1 180	-
Z 32-4 E Riovar	10	1	180	Stratos-D 32/1-8	1 220	Mod. pipe	TOP-ED 32/1-7	1 220	Mod. pipe	Star-RSD 30/6	1 180	-
Z 32-5 E Riovar	10	1	180	Stratos-D 32/1-8	1 220	Mod. pipe	TOP-ED 32/1-7	1 220	Mod. pipe	Star-RSD 30/6	1 180	-
Z 32-6 E/D Riovar	10	1/3	180	Stratos-D 32/1-8	1 220	Mod. pipe	TOP-ED 32/1-7	1 220	Mod. pipe	Star-RSD 30/6	1 180	-

DN 32

Z 30-7 E/D Rio	6/10	1/3	220	Stratos-D 32/1-8	1 220	-	TOP-ED 32/1-7	1 220	-	TOP-SD 32/7	1/3 220	-
Z 30-70 E/D Rio	6/10	1/3	220	Stratos-D 32/1-8	1 220	-	TOP-ED 32/1-7	1 220	-	TOP-SD 32/7	1/3 220	-
Z 32-120 Rio-Eco	6/10	1	220	Stratos-D 32/1-12	1 220	-	-	-	-	-	-	-
Z 32-7 E/D Riovar	6/10	1/3	220	Stratos-D 32/1-8	1 220	-	TOP-ED 32/1-7	1 220	-	TOP-SD 32/7	1/3 220	-
Z 32-70 Rio	6/10	1/3	220	Stratos-D 32/1-8	1 220	-	TOP-ED 32/1-7	1 220	-	TOP-SD 32/7	1/3 220	-
Z 32-70 Riotec	6/10	1/3	220	Stratos-D 32/1-8	1 220	-	TOP-ED 32/1-7	1 220	-	-	-	-
Z 32-80 Rio-Eco	6/10	1	220	Stratos-D 32/1-8	1 220	-	-	-	-	-	-	-
Z 34-2 E/D Riovar	6/10	1/3	220	Stratos-D 32/1-8	1 220	-	TOP-ED 32/1-7	1 220	-	-	-	-

DN 40

A 4 VZ E/D	6/10	1/3	280	Stratos-D 40/1-8	1 220	2x F1	TOP-ED 40/1-7	1 250	F1	TOP-SD 40/7	1/3 250	F1
L 4 Z E/D	6/10	1/3	280	Stratos-D 40/1-8	1 220	2x F1	TOP-ED 40/1-7	1 250	F1	TOP-SD 40/7	1/3 250	F1
M 4 Z D	6/10	3	280	-	-	-	-	-	-	TOP-SD 50/10	3 280	2x F4
Z 40-1/10 Riotec	6/10	1	250	Stratos-D 40/1-12	1 250	-	TOP-ED 40/1-10	1 250	-	-	-	-
Z 40-10 D Rio	6/10	3	250	Stratos-D 40/1-12	1 250	-	TOP-ED 40/1-10	1 250	-	TOP-SD 40/10	3 250	-
Z 40-100 D Rio	6/10	3	250	Stratos-D 40/1-12	1 250	-	TOP-ED 40/1-10	1 250	-	TOP-SD 40/10	3 250	-
Z 40-100 Riotec	6/10	1	250	Stratos-D 40/1-12	1 250	-	TOP-ED 40/1-10	1 250	-	-	-	-
Z 40-120 Rio-Eco	6/10	1	250	Stratos-D 40/1-12	1 250	-	-	-	-	-	-	-
Z 40-7 E/D Rio	6/10	1/3	250	Stratos-D 40/1-8	1 220	F1	TOP-ED 40/1-7	1 250	-	TOP-SD 40/7	1/3 250	-
Z 40-70 E/D Rio	6/10	1/3	250	Stratos-D 40/1-8	1 220	F1	TOP-ED 40/1-7	1 250	-	TOP-SD 40/7	1/3 250	-
Z 40-70 Riotec	6/10	1	250	Stratos-D 40/1-8	1 220	F1	TOP-ED 40/1-7	1 250	-	-	-	-
Z 40-80 Rio-Eco	6/10	1	220	Stratos-D 40/1-8	1 220	-	-	-	-	-	-	-
Z 42-12 E/D Riovar	6/10	1/3	250	Stratos-D 40/1-8	1 220	F1	TOP-ED 40/1-7	1 250	-	TOP-SD 40/7	1/3 250	-
Z 42-17 E/D Riovar	6/10	1/3	250	Stratos-D 40/1-8	1 220	F1	TOP-ED 40/1-7	1 250	-	TOP-SD 40/7	1/3 250	-
Z 42-25 E/D Riovar	6/10	1/3	250	Stratos-D 40/1-8	1 220	F1	TOP-ED 40/1-7	1 250	-	TOP-SD 40/7	1/3 250	-
Z 42-6 E/D Riovar	6/10	1/3	250	Stratos-D 40/1-8	1 220	F1	TOP-ED 40/1-7	1 250	-	TOP-SD 40/7	1/3 250	-
Z 44-18 D Riovar	6/10	3	320	Stratos-D 40/1-8	1 220	2x F26	TOP-ED 40/1-7	1 250	F0+F26+Di	DOP 40/160 r	3 320	-
Z 44-8 E/D Riovar	6/10	1/3	250	Stratos-D 40/1-8	1 220	F1	TOP-ED 40/1-7	1 250	-	DOP 40/100 r	1/3 250	-

*) Energy efficiency class for each type see page 3-5

= Replacement pumps in accordance with EnEV (German Energy Saving Ordinance)

Observe current type (three-phase/single-phase) and nominal pressure of pump (PN 6/PN 10)! — 1 = 1~ 230 V single-phase, 3 = 3~ 400 V three-phase

Check separately whether existing switchgears can be used.

Wilo Replacement Guide Heating

KSB

Twin-head pumps



DN
Type

PN
Motor
Overall length
[mm]

Wilo – new



High-efficiency pumps

Infinitely variable, 1 ~ 230V, 50Hz
Stratos $T_{min}: -10^{\circ}C/T_{max}: 110^{\circ}C$
Stratos ECO $T_{min}: +15^{\circ}C/T_{max}: 110^{\circ}C$

Type

Motor
Overall length
[mm]
Adapter/
Remark



Energy-saving pumps*)

Infinitely variable, 1 ~ 230V,
50Hz
 $T_{max} = 95^{\circ}C$ or $110^{\circ}C$

Type

Motor
Overall length
[mm]
Adapter/
Remark



Standard pumps*)

1-/3-/4-stages
1 ~ 230V or 3 ~ 400V, 50Hz
 $T_{max} = 110^{\circ}C$ or $130^{\circ}C/140^{\circ}C$

Type

Motor
Overall length
[mm]
Adapter/
Remark

DN 50

PN	Motor	Overall length [mm]	Type	Motor	Overall length [mm]	Adapter/Remark	Type	Motor	Overall length [mm]	Adapter/Remark	Type	Motor	Overall length [mm]	Adapter/Remark
L 5 Z E/D	6/10	1/3	340	Stratos-D 50/1-9	1 280	2xF4	TOP-ED 50/1-6	1 280	2xF4	DOP 50/100 r	3 280	-		
L 51 Z E/D	6/10	1/3	340	Stratos-D 50/1-9	1 280	2xF4	TOP-ED 50/1-6	1 280	2xF4	DOP 50/100 r	3 280	2xF4		
M 5 Z D	6/10	3	280	Stratos-D 50/1-9	1 280	-	TOP-ED 50/1-7	1 280	-	TOP-SD 50/7	3 280	-		
Z 50-1/10 Riotec	6/10	1	280	Stratos-D 50/1-12	1 280	-	TOP-ED 50/1-10	1 280	-	-	-	-		
Z 50-1/7 Riotec	6/10	1	280	Stratos-D 50/1-9	1 280	-	TOP-ED 50/1-7	1 280	-	-	-	-		
Z 50-10 D Rio	6/10	3	280	Stratos-D 50/1-12	1 280	-	TOP-ED 50/1-10	1 280	-	TOP-SD 50/10	3 280	-		
Z 50-100 D Rio	6/10	3	280	Stratos-D 50/1-12	1 280	-	TOP-ED 50/1-10	1 280	-	TOP-SD 50/10	3 280	-		
Z 50-100 Riotec	6/10	1	280	Stratos-D 50/1-12	1 280	-	TOP-ED 50/1-10	1 280	-	-	-	-		
Z 50-120 Rio-Eco	6/10	1	280	Stratos-D 50/1-12	1 280	-	-	-	-	-	-	-		
Z 50-60 Riotec	6/10	1	240	Stratos-D 50/1-8	1 240	2xF3	TOP-ED 50/1-6	1 240	-	-	-	-		
Z 50-7 D Rio	6/10	3	280	Stratos-D 50/1-9	1 280	-	TOP-ED 50/1-7	1 280	-	TOP-SD 50/7	3 280	-		
Z 50-70 D Rio	6/10	3	280	Stratos-D 50/1-9	1 280	-	TOP-ED 50/1-7	1 280	-	TOP-SD 50/7	3 280	-		
Z 50-70 Riotec	6/10	1	280	Stratos-D 50/1-9	1 280	-	TOP-ED 50/1-7	1 280	-	-	-	-		
Z 50-80 Rio-Eco	6/10	1	240	Stratos-D 50/1-8	1 240	-	-	-	-	-	-	-		
Z 50-90 Rio-Eco	6/10	1	280	Stratos-D 50/1-9	1 280	-	-	-	-	-	-	-		
Z 52-25 E/D Riovar	6/10	1/3	280	Stratos-D 50/1-8	1 240	2xF3	TOP-ED 50/1-7	1 280	-	TOP-SD 50/7	3 280	-		
Z 52-32 D Riovar	6/10	3	280	Stratos-D 50/1-9	1 280	-	TOP-ED 50/1-7	1 280	-	TOP-SD 50/7	3 280	-		
Z 52-45 D Riovar	6/10	3	280	Stratos-D 50/1-12	1 280	-	TOP-ED 50/1-10	1 280	-	TOP-SD 50/10	3 280	-		
Z 52-85 D Riovar	6/10	3	340	-	-	-	-	-	-	TOP-SD 50/15	3 340	-		
Z 54-18 D Riovar	6/10	3	280	Stratos-D 50/1-8	1 240	2xF3	TOP-ED 50/1-6	1 280	-	DOP 50/100 r	3 280	-		
Z 54-30 D Riovar	6/10	3	340	Stratos-D 50/1-9	1 280	2xF4	TOP-ED 50/1-7	1 280	2xF4	TOP-SD 50/7	3 280	2xF4		

DN 65

PN	Motor	Overall length [mm]	Type	Motor	Overall length [mm]	Adapter/Remark	Type	Motor	Overall length [mm]	Adapter/Remark	Type	Motor	Overall length [mm]	Adapter/Remark
M 6 Z D	6/10	3	340	Stratos-D 65/1-12	1 340	-	TOP-ED 65/1-10	1 340	-	TOP-SD 65/10	3 340	-		
M 61 Z D	6/10	3	340	Stratos-D 65/1-12	1 340	-	TOP-ED 65/1-10	1 340	-	TOP-SD 65/10	3 340	-		
R 6 Z D	6/10	3	340	Stratos-D 65/1-12	1 340	-	DP-E 65/115-1,5/2	3 340	-	TOP-SD 65/13	3 340	-		
Z 62-130 D Riovar	6/10	3	340	Stratos-D 65/1-12	1 340	-	DP-E 65/115-1,5/2	3 340	-	TOP-SD 65/15	3 340	-		
Z 62-40 D Riovar	6/10	3	340	Stratos-D 65/1-12	1 340	-	TOP-ED 65/1-10	1 340	-	TOP-SD 65/10	3 340	-		
Z 62-60 D Riovar	6/10	3	340	Stratos-D 65/1-12	1 340	-	TOP-ED 65/1-10	1 340	-	TOP-SD 65/10	3 340	-		
Z 62-70 D Riovar	6/10	3	340	Stratos-D 65/1-12	1 340	-	TOP-ED 65/1-10	1 340	-	TOP-SD 65/10	3 340	-		
Z 64-30 D Riovar	6/10	3	340	Stratos-D 65/1-12	1 340	-	TOP-ED 65/1-10	1 340	-	DOP 65/125 r	3 340	-		
Z 64-48 D Riovar	6/10	3	340	Stratos-D 65/1-12	1 340	-	TOP-ED 65/1-10	1 340	-	TOP-SD 65/10	3 340	-		
Z 65-1/10 Riotec	6/10	1	340	Stratos-D 65/1-12	1 340	-	TOP-ED 65/1-10	1 340	-	-	-	-		
Z 65-10 D Rio	6/10	3	340	Stratos-D 65/1-12	1 340	-	TOP-ED 65/1-10	1 340	-	TOP-SD 65/10	3 340	-		
Z 65-100 D Rio	6/10	3	340	Stratos-D 65/1-12	1 340	-	TOP-ED 65/1-10	1 340	-	TOP-SD 65/10	3 340	Mod. pipe		
Z 65-100 Riotec	6/10	1	340	Stratos-D 65/1-12	1 340	-	TOP-ED 65/1-10	1 340	-	-	-	-		
Z 65-120 Rio-Eco	6/10	1	340	Stratos-D 65/1-12	1 340	-	-	-	-	-	-	-		
Z 65-13 D Rio	6/10	3	340	-	-	-	DP-E 65/115-1,5/2	3 340	Mod. pipe	TOP-SD 65/13	3 340	-		
Z 65-130 D Rio	6/10	3	340	-	-	-	DP-E 65/115-1,5/2	1 340	Mod. pipe	TOP-SD 65/13	3 340	-		

*) Energy efficiency class for each type see page 3-5

■ = Replacement pumps in accordance with EnEV (German Energy Saving Ordinance)

Observe current type (three-phase/single-phase) and nominal pressure of pump (PN 6/PN 10)! — 1 = 1 ~ 230 V single-phase, 3 = 3 ~ 400 V three-phase

Check separately whether existing switchgears can be used.



KSB			Wilo – new								
Twin-head pumps			High-efficiency pumps Infinitely variable, 1~ 230V, 50Hz Stratos $T_{min}: -10^{\circ}C/T_{max}: 110^{\circ}C$ Stratos ECO $T_{min}: +15^{\circ}C/T_{max}: 110^{\circ}C$			Energy-saving pumps*) Infinitely variable, 1~ 230V, 50Hz $T_{max} = 95^{\circ}C$ or $110^{\circ}C$			Standard pumps*) 1-/3-/4-stages 1~ 230V or 3~ 400V, 50Hz $T_{max} = 110^{\circ}C$ or $130^{\circ}C/140^{\circ}C$		
DN	PN	Motor Overall length [mm]	Type	Motor Overall length [mm]	Adapter/Remark	Type	Motor Overall length [mm]	Adapter/Remark	Type	Motor Overall length [mm]	Adapter/Remark
DN 80											
Z 80-1/10 Riotec	6/10	1 360	Stratos-D 80/1-12	1 360	-	TOP-ED 80/1-10	1 360	-	-	-	-
Z 80-10 D Rio	6/10	3 360	Stratos-D 80/1-12	1 360	-	TOP-ED 80/1-10	1 360	-	TOP-SD 80/10	3 360	-
Z 80-100 D Rio	6/10	3 360	Stratos-D 80/1-12	1 360	-	TOP-ED 80/1-10	1 360	-	TOP-SD 80/10	3 360	-
Z 80-100 Riotec	6/10	1 360	Stratos-D 80/1-12	1 360	-	TOP-ED 80/1-10	1 360	-	-	-	-
Z 80-120 Rio-Eco	6/10	1 360	Stratos-D 80/1-12	1 360	-	-	-	-	-	-	-
Z 82-100 D Riovar	6/10	3 360	Stratos-D 80/1-12	1 360	-	TOP-ED 80/1-10	1 360	-	TOP-SD 80/10	3 360	-
Z 82-130 D Riovar	6/10	3 360	Stratos-D 80/1-12	1 360	-	TOP-ED 80/1-10	1 360	-	TOP-SD 80/10	3 360	-
Z 82-65 D Riovar	6/10	3 360	Stratos-D 80/1-12	1 360	-	TOP-ED 80/1-10	1 360	-	TOP-SD 80/10	3 360	-
Z 82-85 D Riovar	6/10	3 360	Stratos-D 80/1-12	1 360	-	TOP-ED 80/1-10	1 360	-	TOP-SD 80/10	3 360	-
Z 84-48 D Riovar	6/10	3 360	Stratos-D 80/1-12	1 360	-	TOP-ED 80/1-10	1 360	-	DOP 80/125 r	3 360	-
Z 84-75 D Riovar	6/10	3 360	Stratos-D 80/1-12	1 360	-	TOP-ED 80/1-10	1 360	-	TOP-SD 80/10	3 360	-
DN 100											
Z 102-130 D Riovar	6/10	3 395	Stratos-D 80/1-12	1 360	Mod. pipe	DP-E 65/115-2,2/2	3 360	Mod. pipe	TOP-SD 80/10	3 360	Mod. pipe
Z 104-110 D Riovar	6/10	3 395	Stratos-D 80/1-12	1 360	Mod. pipe	TOP-ED 80/1-10	1 360	Mod. pipe	DOP 100/160 r	3 395	-

*) Energy efficiency class for each type see page 3–5

= Replacement pumps in accordance with EnEV (German Energy Saving Ordinance)

Observe current type (three-phase/single-phase) and nominal pressure of pump (PN 6/PN 10)! — 1 = 1~ 230 V single-phase, 3 = 3~ 400 V three-phase
 Check separately whether existing switchgears can be used.

Wilo Replacement Guide Secondary Hot Water Circulation

Wilo				Wilo – new											
Secondary hot water circulating pumps  				High-efficiency pumps Infinitely variable, 1~230V, 50Hz Stratos-Z T _{min} : 0°C/T _{max} : 80°C Stratos ECO-Z T _{min} : +15°C/T _{max} : 65°C				Energy-saving pumps Infinitely variable, 1~230V, 50Hz				Standard pumps 1 or 3 stages 1~230V or 3~400V, 50Hz T _{max} = Star-Z u. TOP-Z 65°C or 80°C IP-Z = 110°C			
DN Type	PN	Motor	Overall length [mm]	Type	Motor	Overall length [mm]	Adapter/Remark	Type	Motor	Overall length [mm]	Adapter/Remark	Type	Motor	Overall length [mm]	Adapter/Remark
R ½															
Star-Z 15	10	1	84	–	–	–	–	–	–	–	–	Star-Z 15 Service motor	1	0	–
Star-Z 15 A APress	10	1	140	–	–	–	–	–	–	–	–	Star-Z 15 Service motor	1	0	–
Star-Z 15 C CPress	10	1	140	–	–	–	–	–	–	–	–	Star-Z 15 Service motor	1	0	–
Star-Z 15 TT TTPress	10	1	140	–	–	–	–	–	–	–	–	Star-Z 15 TT Service motor	1	0	–
Z 15	10	1	84	–	–	–	–	–	–	–	–	Star-Z 15 Service motor	1	0	–
Rp ½ (Pump thread G 1)															
Star-Z 20/1	10	1	140	–	–	–	–	–	–	–	–	Star-Z 20/1	1	140	–
Z 20	10	1	140	–	–	–	–	–	–	–	–	Star-Z 20/1	1	140	–
Z 20/40	10	1	140	–	–	–	–	–	–	–	–	Star-Z 20/1	1	140	–
Rp ¾ (Pump thread G 1½)															
TOP-Z 20/4	10	1/3	150	–	–	–	–	–	–	–	–	TOP-Z 20/4	1/3	150	–
Rp 1 (Pump thread G 1½)															
IL-Z 25/2	10	1/3	180	–	–	–	–	–	–	–	–	IP-Z 25/2	1/3	180	–
IL-Z 25/6	10	1/3	180	–	–	–	–	–	–	–	–	IP-Z 25/6	1/3	180	–
IP-Z 25/2	10	1/3	180	–	–	–	–	–	–	–	–	IP-Z 25/2	1/3	180	–
IP-Z 25/6	10	1/3	180	–	–	–	–	–	–	–	–	IP-Z 25/6	1/3	180	–
Star-Z 25/2	10	1/3	180	Stratos ECO-Z 25/1-5	1	180	–	–	–	–	–	Star-Z 25/2	1/3	180	–
Star-Z 25/6	10	1	180	Stratos ECO-Z 25/1-5	1	180	–	–	–	–	–	Star-Z 25/6	1	180	–
Star-ZE 25/1-5	10	1	180	Stratos ECO-Z 25/1-5	1	180	–	–	–	–	–	–	–	–	–
Star-ZE 25/1-5 SSM	10	1	180	Stratos ECO-Z 25/1-5-BMS	1	180	–	–	–	–	–	–	–	–	–
Stratos ECO-Z 25/1-5	10	1	180	Stratos ECO-Z 25/1-5	1	180	–	–	–	–	–	–	–	–	–
Stratos-Z 25/1-8	10	1	180	Stratos-Z 25/1-8	1	180	–	–	–	–	–	–	–	–	–
TOP-Z 25/10	10	1/3	180	Stratos-Z 30/1-12	1	180	Mod. pipe	–	–	–	–	TOP-Z 25/10	1/3	180	–
TOP-Z 25/6	10	1/3	180	Stratos-Z 25/1-8	1	180	–	–	–	–	–	TOP-Z 25/6	1/3	180	–
Z 25	10	1/3	180	–	–	–	–	–	–	–	–	Star-Z 25/2	1/3	180	–
ZP 25	10	1/3	180	–	–	–	–	–	–	–	–	Star-Z 25/2	1/3	180	–
ZS 25	10	1/3	180	–	–	–	–	–	–	–	–	Star-Z 25/6	1	180	–
Rp 1¼ (Pump thread G 2)															
Stratos-Z 30/1-12	10	1	180	Stratos-Z 30/1-12	1	180	–	–	–	–	–	–	–	–	–
Stratos-Z 30/1-8	10	1	180	Stratos-Z 30/1-8	1	180	–	–	–	–	–	–	–	–	–
TOP-Z 30/10	10	1/3	180	Stratos-Z 30/1-12	1	180	–	–	–	–	–	TOP-Z 30/10	1/3	180	–
TOP-Z 30/7, -Z 30	10	1/3	180	Stratos-Z 30/1-8	1	180	–	–	–	–	–	TOP-Z 30/7	1/3	180	–
Z 30	10	1/3	220	Stratos-Z 30/1-8	1	180	R22	–	–	–	–	TOP-Z 30/7	1/3	180	R22
Z 30 (alle Bauj.)	10	1/3	180	Stratos-Z 30/1-8	1	180	–	–	–	–	–	TOP-Z 30/7	1/3	180	–
ZP 30	10	1/3	220	Stratos-Z 30/1-8	1	180	R22	–	–	–	–	TOP-Z 30/7	1/3	180	R22
ZS 30	10	1/3	220	Stratos-Z 30/1-8	1	180	R22	–	–	–	–	TOP-Z 30/7	1/3	180	R22

■ = Replacement pumps in accordance with EnEV (German Energy Saving Ordinance)

Observe current type (three-phase/single-phase) and nominal pressure of pump (PN 6/PN 10)! — 1 = 1~230 V single-phase, 3 = 3~400 V three-phase

Check separately whether existing switchgears can be used.



Wilo				Wilo – new											
Secondary hot water circulating pumps				High-efficiency pumps Infinitely variable, 1 ~ 230V, 50Hz Stratos-Z $T_{min}: 0^{\circ}C/T_{max}: 80^{\circ}C$ Stratos ECO-Z $T_{min}: +15^{\circ}C/T_{max}: 65^{\circ}C$				Energy-saving pumps Infinitely variable, 1 ~ 230V, 50Hz				Standard pumps 1 or 3 stages 1 ~ 230V or 3 ~ 400V, 50Hz $T_{max} = \text{Star-Z u. TOP-Z } 65^{\circ}C \text{ or } 80^{\circ}C$ IP-Z = 110°C			
DN Type	PN	Motor	Overall length [mm]	Type			Type			Type					
				Motor	Overall length [mm]	Adapter/Remark	Motor	Overall length [mm]	Adapter/Remark	Motor	Overall length [mm]	Adapter/Remark			
DN 40															
Stratos-Z 40/1-12	6/10	1	250	Stratos-Z 40/1-12	1	250	-	-	-	-	-	-			
Stratos-Z 40/1-8	6/10	1	220	Stratos-Z 40/1-8	1	220	-	-	-	-	-	-			
TOP-Z 40/7, -Z 40	6/10	1/3	250	Stratos-Z 40/1-8	1	220	F1-MS	-	-	-	TOP-Z 40/7	1/3 250 -			
Z 40 (v), Z 40 r	6/10	1/3	250	Stratos-Z 40/1-8	1	220	F1-MS	-	-	-	TOP-Z 40/7	1/3 250 -			
ZP 40	6/10	1/3	250	Stratos-Z 40/1-8	1	220	F1-MS	-	-	-	TOP-Z 40/7	1/3 250 -			
DN 50															
Stratos-Z 50/1-9	6/10	1	280	Stratos-Z 50/1-9	1	280	-	-	-	-	-	-			
TOP-Z 50/7, -Z 50	6/10	3	280	Stratos-Z 50/1-9	1	280	-	-	-	-	TOP-Z 50/7	3 280 -			
Z 50 v, Z 50 r	6/10	3	280	Stratos-Z 50/1-9	1	280	-	-	-	-	TOP-Z 50/7	3 280 -			
ZP 50	6/10	3	280	Stratos-Z 50/1-9	1	280	-	-	-	-	TOP-Z 50/7	3 280 -			
ZS 50	6/10	3	280	Stratos-Z 50/1-9	1	280	-	-	-	-	TOP-Z 50/7	3 280 -			
DN 65															
TOP-Z 65/10, -Z 65	6/10	3	340	-	-	-	-	-	-	-	TOP-Z 65/10	3 340 -			
Z 65 v, Z 65 r	6/10	3	340	-	-	-	-	-	-	-	TOP-Z 65/10	3 340 -			
ZP 65	6/10	3	340	-	-	-	-	-	-	-	TOP-Z 65/10	3 340 -			
ZS 65	6/10	3	340	-	-	-	-	-	-	-	TOP-Z 65/10	3 340 -			
DN 80															
TOP-Z 80/10, -Z 80	6/10	3	360	-	-	-	-	-	-	-	TOP-Z 80/10	3 360 -			
Z 80 v, Z 80 r	6/10	3	360	-	-	-	-	-	-	-	TOP-Z 80/10	3 360 -			
ZP 80	6/10	3	360	-	-	-	-	-	-	-	TOP-Z 80/10	3 360 -			
ZS 80	6/10	3	360	-	-	-	-	-	-	-	TOP-Z 80/10	3 360 -			

■ = Replacement pumps in accordance with EnEV (German Energy Saving Ordinance)

Observe current type (three-phase/single-phase) and nominal pressure of pump (PN 6/PN 10)! — 1 = 1 ~ 230 V single-phase, 3 = 3 ~ 400 V three-phase

Check separately whether existing switchgears can be used.

Wilo Replacement Guide Secondary Hot Water Circulation

Grundfos				Wilo – new												
Secondary hot water circulating pumps  				High-efficiency pumps Infinitely variable, 1~ 230V, 50Hz Stratos-Z T _{min} : 0°C/T _{max} : 80°C Stratos ECO-Z T _{min} : +15°C/T _{max} : 65°C				Energy-saving pumps Infinitely variable, 1~ 230V, 50Hz				Standard pumps 1 or 3 stages 1~ 230V or 3~ 400V, 50Hz T _{max} = Star-Z u. TOP-Z 65°C or 80°C IP-Z = 110°C				
				DN Type	PN	Motor	Overall length [mm]	Type	Motor	Overall length [mm]	Adapter/Remark	Type	Motor	Overall length [mm]	Adapter/Remark	Type
R ½																
UP 15-13 B	10	1	86	-	-	-	-	-	-	-	-	-	Star-Z 15 Service motor	1	0	-
UP 15-13 BU	10	1	86	-	-	-	-	-	-	-	-	-	Star-Z 15 TT Service motor	1	0	-
UP 15-13 BX	10	1	130	-	-	-	-	-	-	-	-	-	Star-Z 15 Service motor	1	0	-
UP 15-13 BXU	10	1	130	-	-	-	-	-	-	-	-	-	Star-Z 15 TT Service motor	1	0	-
UP 15-14 B Comfort	10	1	80	-	-	-	-	-	-	-	-	-	Star-Z 15 Service motor	1	0	-
UP 15-14 BT Comfort	10	1	80	-	-	-	-	-	-	-	-	-	Star-Z 15 TT Service motor	1	0	-
UP 15-14 BU Comfort	10	1	80	-	-	-	-	-	-	-	-	-	Star-Z 15 TT Service motor	1	0	-
UP 15-14 BUT Comfort	10	1	80	-	-	-	-	-	-	-	-	-	Star-Z 15 TT Service motor	1	0	-
Rp ¾ (Pump thread G 1¼)																
UM 20-07 N	10	1	150	-	-	-	-	-	-	-	-	-	Star-Z 20/1	1	140	Mod. pipe
UM 24-08 N	10	1	150	-	-	-	-	-	-	-	-	-	Star-Z 20/1	1	140	Mod. pipe
UM 25-08 N	10	1	150	-	-	-	-	-	-	-	-	-	Star-Z 20/1	1	140	Mod. pipe
UM 25-12 N	10	1/3	150	-	-	-	-	-	-	-	-	-	Star-Z 20/1	1	140	Mod. pipe
UP 15-15 N	10	1	150	-	-	-	-	-	-	-	-	-	Star-Z 20/1	1	140	Mod. pipe
UP 15-25 N	10	1	150	-	-	-	-	-	-	-	-	-	Star-Z 20/1	1	140	Mod. pipe
UP 20-07 N, NX	10	1	150	-	-	-	-	-	-	-	-	-	Star-Z 20/1	1	140	Mod. pipe
UP 20-14 BX Comfort	10	1	110	-	-	-	-	-	-	-	-	-	Star-Z 15 Service motor	1	0	-
UP 20-14 BXT Comfort	10	1	110	-	-	-	-	-	-	-	-	-	Star-Z 15 TT Service motor	1	0	-
UP 20-14 BXU Comfort	10	1	110	-	-	-	-	-	-	-	-	-	Star-Z 15 TT Service motor	1	0	-
UP 20-14 BXUT Comfort	10	1	110	-	-	-	-	-	-	-	-	-	Star-Z 15 TT Service motor	1	0	-
UP 20-15 N, NX	10	1/3	150	-	-	-	-	-	-	-	-	-	Star-Z 20/1	1	140	Mod. pipe
UP 20-30 N	10	1/3	150	Stratos ECO-Z 25/1-5	1	180	Mod. pipe	-	-	-	-	-	Star-Z 25/2	1/3	180	Mod. pipe
UP 20-45 N	10	1/3	150	Stratos ECO-Z 25/1-5	1	180	Mod. pipe	-	-	-	-	-	TOP-Z 20/4	1/3	150	-
UP 25-30 N	10	1/3	150	Stratos ECO-Z 25/1-5	1	180	Mod. pipe	-	-	-	-	-	TOP-Z 20/4	1/3	150	-
UP 25-45 N	10	1/3	150	Stratos ECO-Z 25/1-5	1	180	Mod. pipe	-	-	-	-	-	TOP-Z 20/4	1/3	150	-
Rp 1 (Pump thread G 1½)																
Alpha+ 25-40 B	10	1	180	Stratos ECO-Z 25/1-5	1	180	-	-	-	-	-	-	-	-	-	-
Alpha+ 25-60 B	10	1	180	Stratos ECO-Z 25/1-5	1	180	-	-	-	-	-	-	-	-	-	-
UPE 25-40 B	10	1	180	Stratos ECO-Z 25/1-5	0	180	-	-	-	-	-	-	-	-	-	-
UPE 25-60 B	10	1	180	Stratos ECO-Z 25/1-5	0	180	-	-	-	-	-	-	-	-	-	-
UPS 20-60 B	10	1	180	Stratos-Z 25/1-8	1	180	-	-	-	-	-	-	TOP-Z 25/6	1/3	180	-
UPS 25-40 B	10	1	180	Stratos ECO-Z 25/1-5	1	180	-	-	-	-	-	-	Star-Z 25/2	1/3	180	-
UPS 25-60 B	10	1	180	Stratos-Z 25/1-8	1	180	-	-	-	-	-	-	TOP-Z 25/6	1/3	180	-
UPS 25-80 B	10	1	180	Stratos-Z 25/1-8	1	180	-	-	-	-	-	-	TOP-Z 30/7	1/3	180	Mod. pipe

■ = Replacement pumps in accordance with EnEV (German Energy Saving Ordinance)

Observe current type (three-phase/single-phase) and nominal pressure of pump (PN 6/PN 10)! — 1 = 1~230 V single-phase, 3 = 3~400 V three-phase

Check separately whether existing switchgears can be used.



Grundfos				Wilo – new																	
Secondary hot water circulating pumps 				High-efficiency pumps Infinitely variable, 1 ~ 230V, 50Hz Stratos-Z T _{min} : 0°C/T _{max} : 80°C Stratos ECO-Z T _{min} : +15°C/T _{max} : 65°C						Energy-saving pumps Infinitely variable, 1 ~ 230V, 50Hz						Standard pumps 1 or 3 stages 1 ~ 230V or 3 ~ 400V, 50Hz T _{max} = Star-Z u. TOP-Z 65°C or 80°C IP-Z = 110°C					
				DN Type	PN	Motor	Overall length [mm]	Type	Motor	Overall length [mm]	Adapter/Remark	Type	Motor	Overall length [mm]	Adapter/Remark	Type	Motor	Overall length [mm]	Adapter/Remark		
Rp 1 ¼ (Pump thread G 2)																					
Magna 32-100 N	10	1	180	Stratos-Z 30/1-12	1	180	-	-	-	-	-	-	-	-	-	-					
UP 32-80 B	10	3	180	Stratos-Z 30/1-8	1	180	-	-	-	-	-	TOP-Z 30/10	1/3	180	-	-					
UP 40-75 RB	10	1/3	180	Stratos-Z 30/1-8	1	180	-	-	-	-	-	TOP-Z 30/7	1/3	180	-	-					
UPE 32-80 B	10	1	180	Stratos-Z 30/1-8	1	180	-	-	-	-	-	-	-	-	-	-					
UPS 32-80 B	10	1	180	Stratos-Z 30/1-8	1	180	-	-	-	-	-	TOP-Z 30/10	1/3	180	-	-					
UPS 40-80 RB	10	1/3	180	Stratos-Z 30/1-12	1	180	-	-	-	-	-	TOP-Z 30/10	1/3	180	-	-					
DN 32																					
Magna 32-120 FN	6/10	1	220	Stratos-Z 30/1-12	1	180	Mod. pipe	-	-	-	-	-	-	-	-	-					
Magna UPE 32-120 FB	6/10	1	220	Stratos-Z 30/1-12	1	180	Mod. pipe	-	-	-	-	-	-	-	-	-					
Magna UPE 32-120 FN	6/10	1	220	Stratos-Z 30/1-12	1	180	Mod. pipe	-	-	-	-	-	-	-	-	-					
UPE 32-120 FB	6/10	1	220	Stratos-Z 30/1-12	1	180	Mod. pipe	-	-	-	-	-	-	-	-	-					
UPE 32-80 FB	6/10	1	220	Stratos-Z 30/1-8	1	180	Mod. pipe	-	-	-	-	-	-	-	-	-					
UPS 32-120 FB	6/10	1/3	220	Stratos-Z 30/1-12	1	180	Mod. pipe	-	-	-	-	TOP-Z 30/10	1/3	180	Mod. pipe	-					
UPS 32-30 FB	6/10	1/3	220	Stratos-Z 30/1-8	1	180	Mod. pipe	-	-	-	-	TOP-Z 30/7	1/3	180	Mod. pipe	-					
UPS 32-60 FB	6/10	1/3	220	Stratos-Z 30/1-8	1	180	Mod. pipe	-	-	-	-	TOP-Z 30/7	1/3	180	Mod. pipe	-					
DN 40																					
Magna 40-120 FN	6/10	1	250	Stratos-Z 40/1-12	1	250	-	-	-	-	-	-	-	-	-	-					
Magna UPE 40-120 FB	6/10	1	250	Stratos-Z 40/1-12	1	250	-	-	-	-	-	-	-	-	-	-					
Magna UPE 40-120 FN	6/10	1	250	Stratos-Z 40/1-12	1	250	-	-	-	-	-	-	-	-	-	-					
UMC 40-30 B	10	1/3	250	Stratos-Z 40/1-8	1	220	F1-MS	-	-	-	-	TOP-Z 40/7	1/3	250	-	-					
UMS 40-30 B	10	3	250	Stratos-Z 40/1-8	1	220	F1-MS	-	-	-	-	TOP-Z 40/7	1/3	250	-	-					
UP 40-50 FB	6/10	3	250	Stratos-Z 40/1-8	1	220	F1-MS	-	-	-	-	TOP-Z 40/7	1/3	250	-	-					
UP 40-80 FB	6	3	250	Stratos-Z 40/1-8	1	220	F1-MS	-	-	-	-	TOP-Z 40/7	1/3	250	-	-					
UP 42-42 FB	10	1/3	250	Stratos-Z 40/1-8	1	220	F1-MS	-	-	-	-	TOP-Z 40/7	1/3	250	-	-					
UP 42-50 FB	10	3	250	Stratos-Z 40/1-8	1	220	F1-MS	-	-	-	-	TOP-Z 40/7	1/3	250	-	-					
UP 42-80 FB	6	1/3	250	Stratos-Z 40/1-8	1	220	F1-MS	-	-	-	-	TOP-Z 40/7	1/3	250	-	-					
UPC 40-120 B	10	3	250	Stratos-Z 40/1-8	1	220	F1-MS	-	-	-	-	-	-	-	-	-					
UPC 40-60 B	10	3	250	Stratos-Z 40/1-8	1	220	F1-MS	-	-	-	-	TOP-Z 40/7	1/3	250	-	-					
UPE 40-120 (F)B	6/10	1	250	Stratos-Z 40/1-12	1	250	-	-	-	-	-	-	-	-	-	-					
UPE 40-80 FB	6/10	1	250	Stratos-Z 40/1-8	1	220	F1-MS	-	-	-	-	-	-	-	-	-					
UPS 40-120 FB	6/10	1/3	250	Stratos-Z 40/1-8	1	220	F1-MS	-	-	-	-	-	-	-	-	-					
UPS 40-180 FB	6/10	1/3	250	Stratos-Z 40/1-12	1	250	-	-	-	-	-	-	-	-	-	-					
UPS 40-30 FB	6/10	1/3	250	Stratos-Z 40/1-8	1	220	F1-MS	-	-	-	-	TOP-Z 40/7	1/3	250	-	-					
UPS 40-52 FB	10	1	250	Stratos-Z 40/1-8	1	220	F1-MS	-	-	-	-	TOP-Z 40/7	1/3	250	-	-					

■ = Replacement pumps in accordance with EnEV (German Energy Saving Ordinance)

Observe current type (three-phase/single-phase) and nominal pressure of pump (PN 6/PN 10)! — 1 = 1 ~ 230 V single-phase, 3 = 3 ~ 400 V three-phase

Check separately whether existing switchgears can be used.

Wilo Replacement Guide Secondary Hot Water Circulation

Grundfos				Wilo – new													
Secondary hot water circulating pumps  				High-efficiency pumps Infinitely variable, 1~230V, 50Hz Stratos-Z T _{min} : 0°C/T _{max} : 80°C Stratos ECO-Z T _{min} : +15°C/T _{max} : 65°C				Energy-saving pumps Infinitely variable, 1~230V, 50Hz				Standard pumps 1 or 3 stages 1~230V or 3~400V, 50Hz T _{max} = Star-Z u. TOP-Z 65°C or 80°C IP-Z = 110°C					
				DN Type			Type	Motor Overall length [mm] Adapter/Remark			Type	Motor Overall length [mm] Adapter/Remark			Type	Motor Overall length [mm] Adapter/Remark	
PN	Motor	Overall length [mm]															
DN 40																	
UPS 40-60 B	10	3	250	Stratos-Z 40/1-8	1	220	F1-MS	-	-	-	-	TOP-Z 40/7	1/3	250	-		
UPS 40-60/2 FB	6/10	1/3	250	Stratos-Z 40/1-8	1	220	F1-MS	-	-	-	-	TOP-Z 40/7	1/3	250	-		
UPS 40-60/4 FB	6/10	1/3	250	Stratos-Z 40/1-8	1	220	F1-MS	-	-	-	-	TOP-Z 40/7	1/3	250	-		
UPS 42-50 FB	6/10	1/3	250	Stratos-Z 40/1-8	1	220	F1-MS	-	-	-	-	TOP-Z 40/7	1/3	250	-		
DN 50																	
Magna 50-120 FN	6/10	1	280	-	-	-	-	-	-	-	-	-	-	-	-	-	-
Magna 50-60 FN	6/10	1	280	Stratos-Z 50/1-9	1	280	-	-	-	-	-	-	-	-	-	-	-
Magna UPE 50-120 FN	6/10	1	280	Stratos-Z 50/1-9	1	280	-	-	-	-	-	-	-	-	-	-	-
Magna UPE 50-60 FB	6/10	1	280	Stratos-Z 50/1-9	1	280	-	-	-	-	-	-	-	-	-	-	-
Magna UPE 50-60 FN	6/10	1	250	Stratos-Z 50/1-9	1	280	Mod. pipe	-	-	-	-	-	-	-	-	-	-
UMC 50-30 B	10	3	280	Stratos-Z 50/1-9	1	280	-	-	-	-	-	TOP-Z 50/7	3	280	-		
UMC 50-60 B	10	3	280	Stratos-Z 50/1-9	1	280	-	-	-	-	-	TOP-Z 50/7	3	280	-		
UMS 50-30 B	10	3	280	Stratos-Z 50/1-9	1	280	-	-	-	-	-	TOP-Z 50/7	3	280	-		
UMS 50-60 B	10	3	280	Stratos-Z 50/1-9	1	280	-	-	-	-	-	TOP-Z 50/7	3	280	-		
UPC 50-120 B	10	3	280	-	-	-	-	-	-	-	-	-	-	-	-	-	-
UPC 50-60 B	10	3	280	Stratos-Z 50/1-9	1	280	-	-	-	-	-	TOP-Z 50/7	3	280	-		
UPE 50-120 (F)B	6/10	3	280	-	-	-	-	-	-	-	-	-	-	-	-	-	-
UPE 50-60 (F)B	6/10	1	280	Stratos-Z 50/1-9	1	280	-	-	-	-	-	-	-	-	-	-	-
UPE 50-80 (F)B	6/10	1	280	Stratos-Z 50/1-9	1	280	-	-	-	-	-	-	-	-	-	-	-
UPS 50-120 FB	6/10	1/3	280	Stratos-Z 50/1-9	1	280	-	-	-	-	-	-	-	-	-	-	-
UPS 50-180 FB	6/10	1/3	280	-	-	-	-	-	-	-	-	-	-	-	-	-	-
UPS 50-30 FB	6/10	1/3	280	Stratos-Z 50/1-9	1	280	-	-	-	-	-	TOP-Z 50/7	3	280	-		
UPS 50-60 B	6/10	1/3	280	Stratos-Z 50/1-9	1	280	-	-	-	-	-	TOP-Z 50/7	3	280	-		
UPS 50-60/2 FB	6/10	1/3	280	Stratos-Z 50/1-9	1	280	-	-	-	-	-	TOP-Z 50/7	3	280	-		
UPS 50-60/4 FB	6/10	1/3	280	Stratos-Z 50/1-9	1	280	-	-	-	-	-	TOP-Z 50/7	3	280	-		

■ = Replacement pumps in accordance with EnEV (German Energy Saving Ordinance)

Observe current type (three-phase/single-phase) and nominal pressure of pump (PN 6/PN 10)! — 1 = 1~230 V single-phase, 3 = 3~400 V three-phase

Check separately whether existing switchgears can be used.

Grundfos				Wilo – new											
Secondary hot water circulating pumps				High-efficiency pumps Infinitely variable, 1 ~ 230V, 50Hz Stratos-Z $T_{min}: 0^{\circ}C/T_{max}: 80^{\circ}C$ Stratos ECO-Z $T_{min}: +15^{\circ}C/T_{max}: 65^{\circ}C$				Energy-saving pumps Infinitely variable, 1 ~ 230V, 50Hz				Standard pumps 1 or 3 stages 1 ~ 230V or 3 ~ 400V, 50Hz $T_{max} = \text{Star-Z u. TOP-Z } 65^{\circ}C \text{ or } 80^{\circ}C$ IP-Z = 110°C			
DN Type	PN	Motor	Overall length [mm]	Type			Type			Type			Type		
				Motor	Overall length [mm]	Adapter/Remark	Motor	Overall length [mm]	Adapter/Remark	Motor	Overall length [mm]	Adapter/Remark	Motor	Overall length [mm]	Adapter/Remark
DN 65															
Magna 65-120 FN	6/10	1	340	-	-	-	-	-	-	-	-	-	-	-	-
Magna 65-60 FN	6/10	1	340	-	-	-	-	-	-	-	-	-	-	-	-
Magna UPE 65-120 FN	6/10	1	340	-	-	-	-	-	-	-	-	-	-	-	-
Magna UPE 65-60 FB	6/10	1	340	-	-	-	-	-	-	-	-	-	-	-	-
UMC 65-30 B	10	3	340	-	-	-	-	-	-	-	-	TOP-Z 65/10	3	340	-
UMC 65-60 B	10	3	340	-	-	-	-	-	-	-	-	TOP-Z 65/10	3	340	-
UMS 65-30 B	10	3	340	-	-	-	-	-	-	-	-	TOP-Z 65/10	3	340	-
UMS 65-60 B	10	3	340	-	-	-	-	-	-	-	-	TOP-Z 65/10	3	340	-
UPC 65-120 B	10	3	340	-	-	-	-	-	-	-	-	TOP-Z 65/10	3	340	-
UPC 65-60 B	10	3	340	-	-	-	-	-	-	-	-	TOP-Z 65/10	3	340	-
UPE 65-120 FB	6/10	3	340	-	-	-	-	-	-	-	-	-	-	-	-
UPE 65-60 (F)B	6/10	1	340	-	-	-	-	-	-	-	-	-	-	-	-
UPS 65-120 FB	6/10	1/3	340	-	-	-	-	-	-	-	-	-	-	-	-
UPS 65-180 FB	6/10	3	340	-	-	-	-	-	-	-	-	-	-	-	-
UPS 65-30 FB	6/10	1/3	340	-	-	-	-	-	-	-	-	TOP-Z 65/10	3	340	-
UPS 65-60 B	6/10	1/3	340	-	-	-	-	-	-	-	-	TOP-Z 65/10	3	340	-
UPS 65-60/2 FB	6/10	1/3	340	-	-	-	-	-	-	-	-	TOP-Z 65/10	3	340	-
UPS 65-60/4 FB	6/10	1/3	340	-	-	-	-	-	-	-	-	TOP-Z 65/10	3	340	-
DN 80															
UMC 80-30 B	10	3	360	-	-	-	-	-	-	-	-	TOP-Z 80/10	3	360	-
UMC 80-60 B	10	3	360	-	-	-	-	-	-	-	-	TOP-Z 80/10	3	360	-
UMS 80-30 B	10	3	360	-	-	-	-	-	-	-	-	TOP-Z 80/10	3	360	-
UMS 80-60 B	10	3	360	-	-	-	-	-	-	-	-	TOP-Z 80/10	3	360	-
UPC 80-120 B	10	3	360	-	-	-	-	-	-	-	-	TOP-Z 80/10	3	360	-
UPE 80-120 (F)B	6	3	360	-	-	-	-	-	-	-	-	-	-	-	-
UPS 80-120 FB	10	3	360	-	-	-	-	-	-	-	-	TOP-Z 80/10	3	360	-
UPS 80-30 FB	10	3	360	-	-	-	-	-	-	-	-	TOP-Z 80/10	3	360	-
UPS 80-60 FB	10	3	360	-	-	-	-	-	-	-	-	TOP-Z 80/10	3	360	-
DN 100															
UPE 100-160 (F)B	6	3	450	-	-	-	-	-	-	-	-	-	-	-	-
UPS 100-30 FB	10	3	450	-	-	-	-	-	-	-	-	-	-	-	-

■ = Replacement pumps in accordance with EnEV (German Energy Saving Ordinance)

Observe current type (three-phase/single-phase) and nominal pressure of pump (PN 6/PN 10)! — 1 = 1 ~ 230 V single-phase, 3 = 3 ~ 400 V three-phase

Check separately whether existing switchgears can be used.

Wilo Replacement Guide Secondary Hot Water Circulation

KSB

Secondary hot water circulating pumps



DN Type

PN
Motor
Overall length [mm]

Wilo – new

High-efficiency pumps

Infinitely variable, 1~230V, 50Hz
Stratos-Z T_{min}: 0°C/T_{max}: 80°C
Stratos ECO-Z T_{min}: +15°C/T_{max}: 65°C

Type
Motor
Overall length [mm]
Adapter/
Remark

Energy-saving pumps

Infinitely variable, 1~230V, 50Hz

Type
Motor
Overall length [mm]
Adapter/
Remark

Standard pumps

1 or 3 stages
1~230V or 3~400V, 50Hz
T_{max} = Star-Z u. TOP-Z 65°C or 80°C
IP-Z = 110°C

Type
Motor
Overall length [mm]
Adapter/
Remark

Rp ½ (Pump thread G 1)

C 20-10E	10	1	140	-	-	-	-	-	-	Star-Z 20/1	1	140	-
R 12-1 E	10	1	140	-	-	-	-	-	-	Star-Z 20/1	1	140	-

Rp ¾ (Pump thread G 1½)

C 12/15	10	1	150	-	-	-	-	-	-	Star-Z 20/1	1	140	Mod. pipe
C 12/15 T	10	1	150	-	-	-	-	-	-	Star-Z 20/1	1	140	Mod. pipe
C 12/30	10	1	150	-	-	-	-	-	-	Star-Z 25/2	1/3	180	Mod. pipe
C 12/30 T	10	1	150	-	-	-	-	-	-	Star-Z 25/2	1/3	180	Mod. pipe
C 20-15	10	1	150	-	-	-	-	-	-	Star-Z 20/1	1	140	Mod. pipe
C 20-30	10	1	150	-	-	-	-	-	-	Star-Z 25/2	1/3	180	Mod. pipe

Rp 1 (Pump thread G 1½)

C 22/40	10	1	180	Stratos ECO-Z 25/1-5	1	180	-	-	-	Star-Z 25/6	1	180	-
C 22/40 T	10	1	180	Stratos ECO-Z 25/1-5	1	180	-	-	-	Star-Z 25/6	1	180	-
C 22/55	10	1	180	Stratos ECO-Z 25/1-5	1	180	-	-	-	Star-Z 25/6	1	180	-
C 22/55 T	10	1	180	Stratos ECO-Z 25/1-5	1	180	-	-	-	Star-Z 25/6	1	180	-
C 25-40	10	1	180	Stratos ECO-Z 25/1-5	1	180	-	-	-	Star-Z 25/6	1	180	-
C 25-60	10	1	180	Stratos ECO-Z 25/1-5	1	180	-	-	-	Star-Z 25/6	1	180	-
R 22-2 E	10	1	180	Stratos ECO-Z 25/1-5	1	180	-	-	-	Star-Z 25/2	1/3	180	-

Rp 1¼ (Pump thread G 2)

BZ 1 E/D	10	1/3	180	-	-	-	-	-	-	Star-Z 25/2	1/3	180	Mod. pipe
BZ 2 E/D	10	1/3	180	Stratos-Z 30/1-8	1	180	-	-	-	TOP-Z 30/7	1/3	180	-
C 30-70	10	1/3	180	Stratos-Z 30/1-8	1	180	-	-	-	TOP-Z 30/7	1/3	180	-
G 22-5 E/D	10	1/3	180	Stratos ECO-Z 25/1-5	1	180	Mod. pipe	-	-	Star-Z 25/2	1/3	180	Mod. pipe
G 22-8 E/D	10	1/3	180	Stratos ECO-Z 25/1-5	1	180	Mod. pipe	-	-	Star-Z 25/2	1/3	180	Mod. pipe
GG 1 E/D	10	1/3	180	Stratos ECO-Z 25/1-5	1	180	Mod. pipe	-	-	Star-Z 25/2	1/3	180	Mod. pipe
G 24-3 E/D	10	1/3	180	Stratos-Z 30/1-8	1	180	-	-	-	TOP-Z 30/7	1/3	180	-
G 32-12 E/D	10	1/3	180	Stratos-Z 30/1-8	1	180	-	-	-	TOP-Z 30/7	1/3	180	-
GG 2 E/D	10	1/3	180	Stratos-Z 30/1-8	1	180	-	-	-	TOP-Z 30/7	1/3	180	-
R 22-5 E/D	10	1/3	180	Stratos ECO-Z 25/1-5	1	180	Mod. pipe	-	-	Star-Z 25/2	1/3	180	Mod. pipe
R 22-8 E/D	10	1/3	180	Stratos ECO-Z 25/1-5	1	180	Mod. pipe	-	-	Star-Z 25/2	1/3	180	Mod. pipe
RG 1 E/D	10	1/3	180	Stratos ECO-Z 25/1-5	1	180	Mod. pipe	-	-	Star-Z 25/2	1/3	180	Mod. pipe
R 24-3 E/D	10	1/3	180	Stratos-Z 30/1-8	1	180	-	-	-	TOP-Z 30/7	1/3	180	-
R 32-4 E/D	10	1/3	180	Stratos-Z 30/1-8	1	180	-	-	-	TOP-Z 30/7	1/3	180	-
R 32-12 E/D	10	1/3	180	Stratos-Z 30/1-8	1	180	-	-	-	TOP-Z 30/7	1/3	180	-
RG 2 E/D	10	1/3	180	Stratos-Z 30/1-8	1	180	-	-	-	TOP-Z 30/7	1/3	180	-

DN 40

G 40-17 E/D	10	1/3	250	Stratos-Z 40/1-8	1	220	F1-MS	-	-	TOP-Z 40/7	1/3	250	-
R 40-17 E/D	10	1/3	250	Stratos-Z 40/1-8	1	220	F1-MS	-	-	TOP-Z 40/7	1/3	250	-
G 42-17 E/D	10	1/3	250	Stratos-Z 40/1-8	1	220	F1-MS	-	-	TOP-Z 40/7	1/3	250	-
R 42-17 E/D	10	1/3	250	Stratos-Z 40/1-8	1	220	F1-MS	-	-	TOP-Z 40/7	1/3	250	-

DN 50

C 50-70 DGG	6/10	3	280	Stratos-Z 50/1-9	1	280	-	-	-	TOP-Z 50/7	3	280	-
--------------------	------	---	-----	-------------------------	---	-----	---	---	---	-------------------	---	-----	---

■ = Replacement pumps in accordance with EnEV (German Energy Saving Ordinance)

Observe current type (three-phase/single-phase) and nominal pressure of pump (PN 6/PN 10)! — 1 = 1~230 V single-phase, 3 = 3~400 V three-phase

Check separately whether existing switchgears can be used.

Wilco-R, Wilco-RF, Wilco-F

Adapters for length compensation Wilco - (R)

New pump		Pipe			Material	Description	Weight approx. [kg]	Article No.	
DN	G	C	DN	l ₁					l ₂
DN 25	G 1½	G 1½	25	18	20	C.I.	R 24	0,2	110 880 596
DN 25	G 1½	G 1½	25	28	30	C.I.	R 1	0,3	110 786 891
DN 25	G 1½	G 1½	25	38	40	C.I.	R 2	0,5	110 626 790
DN 25	G 1½	G 2	32	3	5	Brass	R 5	0,1	110 678 298
DN 25	G 1½	G 2	32	13	15	C.I.	R 6	0,3	110 678 493
DN 25	G 1½	G 2	32	18	20	C.I.	R 7	0,4	110 787 094
DN 25	G 1½	G 2¼	40	3	5	Brass	R 12	0,1	110 788 294
DN 32	G 2	G 2	32	18	20	C.I.	R 8	0,3	110 627 199
DN 32	G 2	G 2	32	23	25	C.I.	R 9	0,4	110 627 291
DN 32	G 2	G 2	32	28	30	C.I.	R 10	0,5	110 627 394
DN 32	G 2	G 2	32	38	40	C.I.	R 14	0,6	110 627 497
DN 32	G 2	G 2	32	38	40	R.B.	R 22	0,8	110 680 092
DN 32	G 2	G 2	32	68	70	C.I.	R 11	1,0	110 627 590

Note: The Article No. comprises: 1 adapter and 2 seals

Wilco - (R)

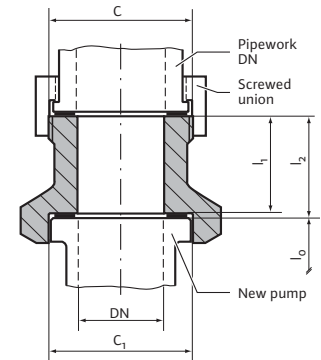

Flanged ring/adapters Wilco-(RF)

The Wilco-(RF) adapters are, apart from some exceptions, for compensating the length with PN 6 flanges (RF 4, RF 5 and RF 6 also in PN 16). Length compensation with PN 10/16 flanges requires onsite pipe alterations.

Threaded flange (RF)

New pump		Pipe	Design			Material	Description	Weight approx. [kg]	Article No.		
DN	G	C	-	l ₁	l ₂				-	-	PN 6/ PN16
DN 25	G 1½	DN 25 (oval flange)	II	-	-	C.I.	RF 7	0.4/-	110 628 790	Hole-circle Ø 80	
DN 25	G 1½	DN 25	I	25,5	30	C.I.	RF 10	1.0/-	110 851 499	-	
DN 25	G 1½	DN 40	I	15,5	20	C.I.	RF 9	1.4/-	110 679 395	-	
DN 25	G 1½	DN 50	I	25,5	30	C.I.	RF 13	1.9/-	110 679 498	-	
DN 32	G 2	DN 32	II	-	-	C.I.	RF 1	1.0/-	110 627 990	-	
DN 32	G 2	DN 32	I	2,5	7	C.I.	RF 2	1.4/-	110 680 298	-	
DN 32	G 2	DN 32	I	15,5	20	C.I.	RF 3	1.4/-	110 680 596	-	
DN 32	G 2	DN 32	I	30,5	35	C.I.	RF 4	2,5/2,7	110 680 699	110680791	
DN 32	G 2	DN 40	II	-	-	C.I.	RF 0	1.3/-	110 679 796	-	
DN 32	G 2	DN 40 (square flange)	I	5,5	10	C.I.	RF 8	0.9/-	110 680 997	Hole-circle Ø 90	
DN 32	G 2	DN 40	I	5,5	10	C.I.	RF 12	1.6/-	110 851 797	-	
DN 32	G 2	DN 50	II	-	-	C.I.	RF 11	1.7/-	110 679 899	-	
DN 32	G 2	DN 50	I	15,5	20	C.I.	RF 5	2,8/3,1	110 787 197	110791299	
DN 32	G 2	DN 50	I	30,5	35	C.I.	RF 6	3,0/3,3	110 787 290	110791391	

Note: The Article No. comprises: 1 flanged ring, 2 seals and screws

Wilco - (RF)

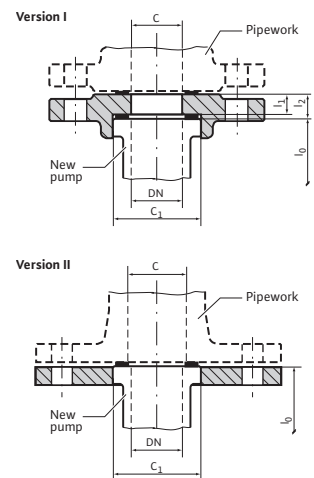

Adapters

Wilco-R, Wilco-RF, Wilco-F

Intermediate flanged piece/adapters Wilco-(F)

The Wilco-F adapters are for compensating the length with PN 6 or PN 16 flanges.

If some adapters are not available, the pipe needs to be modified.

Pumps with combination flanges require the use of washers which are included in the delivery.

Single-ended flanged nipple F1-MS in brass CW 612 N

approved for secondary hot water circulation circuits.

Intermediate flange piece for length compensation Wilco - (F)

New pump DN	Pipe C	l ₁	l ₂	Ød	Material	Description	Weight approx. [kg]	Article No.	
								PN 6	PN 16
DN 40	DN 40	13	15	91	C.I.	F 0	0,8/1,1	110 842 497	110 842 590
DN 40	DN 40	28	30	91	C.I.	F 1	1,4/1,7	110 586 593	110 586 696
DN 40	DN 40	28	30	90	Brass	F1-MS	1,4/1,9	2 060 865	2 060 920
DN 50	DN 50	8	10	106	C.I.	F 2	0,7/0,9	110 787 690	110 791 494
DN 50	DN 50	18	20	106	C.I.	F 3	1,1/1,4	110 623 098	110 623 190
DN 50	DN 50	28	30	106	C.I.	F 4	1,7/2,0	110 681 292	110 681 395
DN 50	DN 50	33	35	126	C.I.	F 5	1,9/2,2	110 623 293	110 623 396
DN 65	DN 65	8	10	126	C.I.	F 9	0,8/1,1	110 787 896	110 791 690
DN 65	DN 65	18	20	126	C.I.	F 10	1,5/1,8	110 624 092	110 624 195
DN 65	DN 65	28	30	141	C.I.	F 11	2,2/2,5	110 624 298	110 624 390
DN 80	DN 80	8	10	91	C.I.	F 16	0,9/-	110 788 099	-
DN 80	DN 80	18	20	126	C.I.	F 17	2,1/-	110 625 097	-
DN 80	DN 80	38	40	141	C.I.	F 18	3,7/-	110 625 292	-
DN 40	DN 40	48	50	106	C.I.	F 26	2,1/2,4	110 851 098	110 851 190
DN 65	DN 65	38	40	141	C.I.	F 28	2,8/3,1	110 681 498	110 681 590
DN 65	DN 65	43	45	141	C.I.	F 29	3,1/3,4	110 681 693	110 681 796
DN 80	DN 80	23	25	126	C.I.	F 30	2,4/3,3	110 681 899	110 681 991
DN 100	DN 100	33	35	161	C.I.	F 34	3,9/-	110 851 293	-
DN 100	DN 100	53	55	161	C.I.	F 35	5,7/-	110 862 592	-

Note: The Article No. comprises: 1 adapter, 2 seals and screws

Wilco - (F)

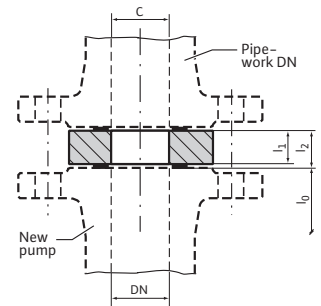

Wilco-R, Wilco-RF, Wilco-F

Same pipe connection of old and new pump

Conne- tion of old pump	Conne- tion of new Wilco pump	New Wilco replacement pump is by the following overall length difference ΔL_0 [mm] shorter																
		0	5	10	15	20	25	30	35	40	45	50	55	60	70	80	90	100
		[mm]																
G 1½	G 1½			S.		R24		R1		R2		R1+R24						
G 2	G 2			S.		R8	R9	R10		R14 or R22 (RG)	R8+R9	2xR9	R9+ R10	2x R10	R11	2x R14	R8+ R11	R10+ R11
DN 40	DN 40				F0			F1 F1-MS				F26		2xF1 2xF1-MS	F0 + F26 + S.			2xF26
DN 50	DN 50			F2		F3		F4	F5	2xF3	F2+ F5	F3+ F4	F3+F5	2xF4	2xF5			
DN 65	DN 65			F9		F10		F11		F28	F29	F10+ F11		2xF11	F11+ F28	2xF28	F28+ F29	
DN 80	DN 80			F16		F17	F30	F16+ F17		F18		2xF30		F17+ F18	F18+ F30	2xF18		
DN 100	DN 100								F34					F35		2xF34		F34+ F35

The intermediate single-ended flange nipples Wilco-F are available in the nominal widths DN 40 to DN 65 in versions PN6 and PN10.

Smaller pipe connection of new Wilco pump

Conne- tion of old pump	Conne- tion of new Wilco pump	New Wilco replacement pump is by the following overall length difference ΔL_0 [mm] shorter																
		0	5	10	15	20	25	30	35	40	45	50	55	60	70	80	90	100
		[mm]																
G 2	G 1½			2xR5 (MS)				2xR6		2xR7								
G 2¼	G 1½			2x R12 (MS)														
DN 25 Oval flange	G 1½	2x RF7				2x RF7 + R24		2x RF7 + R1		2x RF7 + R2								
DN 25	G 1½													2x RF10		2x RF10+ R24		2x RF10+ R2
DN 32	G 2	2x RF1			2x RF2	RF1+R F3			RF1+R F4	2x RF3			RF3+R F4		2x RF4			
DN 40 square end flange	G 2					2x RF8				2x RF8 + R8	2x RF8 + R9	2x RF8 + R10		2x RF8 + R14				
DN 40	G 1½									2x RF9								
DN 40	G 2	2x RF0		RF0+R F12		2x RF12		2x RF0 + R10		2x RF0 + R14				2x RF12+ R14	2x RF12+ F26			
DN 50	G 1½													2x RF13		2x RF13+ R24	2x RF13+ R1	2x RF13+ R2
DN 50	G 2	2x RF11				RF11+ RF5		2x RF11+ R10		2x RF5		RF11+ RF5+ R10	RF5+R F6		2x RF6			

S. = Seal

The adapters Wilco-RF and Wilco-F are, apart from some exceptions (see previous page) for compensating the length with PN 6 or PN 10/16 flanges.

If some adapters are not available, the pipe needs to be modified.

Technical notes for the replacement

Installation position

The Wilo pump is to be installed free of any stress (at all operating conditions) with horizontal shaft in the pipe while the terminal box is on the top or on the side.

Exception:



- Install energy-saving pumps with the terminal box on the top.
- As the terminal boxes of TOP-ED- and TOP-SD pumps are turned by 10°, they must only be installed with their flow direction leading to the top.

Up to a nominal width of DN 65 all pumps of the Stratos/Stratos-D/Stratos-Z as well as the TOP-E/-ED/-S/-SD/-Z series are equipped with combination flanges PN 6/10. The washers included in the delivery have to be used. It is not allowed to install a combination flange to another combination flange.

Residual current protection

Wilo pumps can be used without restriction in existing installations **with and without fuse**.

Note:

For **high-efficiency and energy-saving pumps with single-phase connection** (Stratos, Stratos-D, Stratos-Z, TOP-E and TOP-ED), the operation on residual-current devices in accordance with DIN EN 61008-1 is permitted without any impairment of the RCD function (DIN VDE 0160). Suitable RCD circuit-breakers are identified by  or  .

For **energy-saving pumps with three-phase current connection** (IP-E/DP-E series), the RCD protective circuit has to be selectively universal-current-sensitive (300 mA breaking current).

Stratos/TOP-modules

Stratos and TOP-E single-head pumps

IF-Module for Stratos, TOP-E/-EV single-head pumps (monitoring).

With digital interface for data exchange of control commands and messages.

Stratos-D and TOP-ED twin-head pump

Stratos-D, TOP-ED pump with 2 IF-Modules (pumps with monitoring)

For connection and for data exchange between the two IF-Modules (accessories), the connection cable (0.7 m, 2-core) which is included in the scope of delivery of the IF-Module has to be connected in the terminal boxes of the pumps.

Electrical connection

Connection of a single-phase pump 1 ~ 230 V to a three-phase mains 3 ~ 400 V

Between any phase (L1, L2 or L3) and the neutral conductor N, the voltage is $U = 230 \text{ V}$.

If there is no neutral conductor N, a new line with a neutral conductor has to be laid.

Connecting a single-phase pump to a three-phase mains

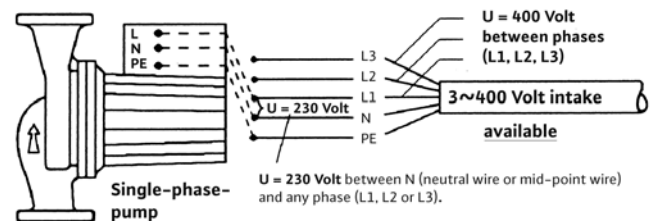

Pump operation

Pump control

- When operating Wilo pumps with control units or module accessories, it is essential to adhere to the electrical operating conditions as set out in VDE 0160.
- When operating pumps in conjunction with **frequency converter makes not supplied by Wilo**, it is necessary to use **output filters** to reduce motor noise and prevent harmful voltage peaks and to adhere to the following limit values:

- **Glandless pumps $P_2 \leq 1.3 \text{ kW}$ and glanded pumps $P_2 \leq 1.1 \text{ kW}$**

- **Voltage peaks** $\hat{u} < 650 \text{ V}$
- **Speed of voltage rise** $du/dt < 500 \text{ V}/\mu\text{s}$

For noise suppression on glandless pumps, it is recommended to use sine filters (LC filters) rather than du/dt filters (RC filters).

- **Glanded pumps $P_2 > 1.1 \text{ kW}$**

- **Voltage peaks** $\hat{u} < 850 \text{ V}$
- **Speed of voltage rise** $du/dt < 500 \text{ V}/\mu\text{s}$

Installations with large cable lengths ($> 10 \text{ m}$) between converter and motor may cause increases of the du/dt- and \hat{u} -levels (resonance). The same may happen for operations with more than 4 motor units at one voltage source.

The output filters must be selected as recommended by the converter manufacturer or filter supplier respectively. The pumps must be operated at max. 95 % of their rated speed if the frequency converter causes motor losses.

When operating standard pumps of the TOP-S/-SD/-D/-Z series with a frequency converter, the following limit values at the connection clamps under-run:

$$U_{\min} = 150 \text{ V}, f_{\min} = 30 \text{ Hz}.$$

Technical notes for the replacement

Motor protection Stratos/TOP series

Motor overload protection of Stratos- and TOP pumps can be ensured as follows:

- **Blocking-current proof motors:
no motor protection required**

The motors are designed in such a way that the windings are not damaged in the event of overload. This holds true for TOP-S/-SD/TOP-Z pumps both in single-phase and in three-phase version with a max. rated power $P_2 = 90$ Watt. For TOP-D with $P_2 \leq 20$ W.

- **Pumps with full motor protection (WSK) and Wilo tripping unit SK 602/622**

Realisation of full motor protection by means of thermal winding contacts (WSK) placed within the stator windings.

This holds true for TOP-S/-SD/-Z single-phase pumps with a rated motor power of $P_2 \geq 180$ Watt. For TOP-D with $P_2 \geq 60$ W.

- **Pumps with integrated full motor protection incl. trip electronics**

Patented motor protection with integrated trip mechanism in the terminal box as standard in all TOP-S/-SD/-Z-three-phase pumps from $P_2 < 180$ Watt and in all TOP-E/-ED/Stratos pumps.

Permanent full motor protection thanks to motor temperature monitoring in the winding.

In the event of a fault, e.g. unacceptable motor heating due to blocking, 2-phase operation, etc., TOP-S/-SD/-Z pumps are shut down by means of a three-phase deactivation in the pump motor terminal box and TOP-E pumps are shut down by means of deactivation of the frequency converter.

A release must be effected by pushing the confirmation button at the terminal box on all TOP pumps.

Connection Wilo-TOP... and -Stratos ... to Wilo switchgears existing on site

Connection Wilo-TOP... and -Stratos ... to Wilo switchgears existing on site

New pump type	Switchbox connection possible as per wiring diagram												Accessories: Modules			
	Wilo-TOP-S Wilo-TOP-Z				Wilo-TOP-SD or 2 x Wilo-TOP-S				Wilo-TOP-D				Wilo-TOP-E Stratos Stratos-Z	Wilo-TOP-ED Stratos-D or 2 x TOP-E 2 x Stratos 2 x Stratos-Z	Wilo-TOP-E Stratos Stratos-Z	Wilo-TOP-ED Stratos-D or 2 x TOP-E 2 x Stratos 2 x Stratos-Z
	1~		3~		1~		3~		1~		3~		1~	1~	1~	1~
Existing Wilo switchgear	IS	WSK	IS	SSM	IS	WSK	IS	SSM	IS	WSK	IS	WSK				
SK 601	A	B	C ¹⁾	D ¹⁾	A	B	C ¹⁾	D ¹⁾	U	W	Y ¹⁾	Z	S	S	Yes	Yes
SK 602/622	F	C	H	I	F	C	H	I	V	X	Y1	Z1	J	J	Yes	Yes
SK 632	-	-	K	L	-	-	K	L	-	-	K	L	-	-	Yes	Yes
S2R 0,2-1	Switchbox not suitable with Wilo-TOP pumps. Alternatively use exchange motor for faulty pump.															
S2R 2,5	Switchbox not suitable with Wilo-TOP pumps. Alternatively use exchange motor for faulty pump.															
S2R 3D	-	-	-	-	M	N	O	P	-	-	-	-	-	Q or R	Yes	Yes
S4R 2,5	Switchbox not suitable with Wilo-TOP pumps. Alternatively use exchange motor for faulty pump.															
S4R 2.5d	Switchbox not suitable with Wilo-TOP pumps. Alternatively use exchange motor for faulty pump.															
AS 08/1.5(µP)	-	S	-	T	-	-	-	-	-	-	-	-	-	-	-	-
2 pieces AS 08/1.5(µP)	-	-	-	-	-	S	-	T	-	-	-	-	-	-	-	-
AS 08/1.5(µP) plus S2R 3D	-	-	-	-	-	N + S	-	P + T	-	-	-	-	-	-	-	-
AR/DR/CR	-	-	-	T	-	-	-	T	-	-	-	-	-	-	-	-

IS: Internal protection against unacceptably high winding temperatures, WSK: Thermal winding contacts, SSM: Collective fault signal

- = Connection not possible.

¹⁾ Only in conjunction with contactor or Wilo-SK 602/622;
SK602/622 can also be used as On/Off switch or contactor

Circuit diagram A
Mains 1~230 V/N/50 Hz

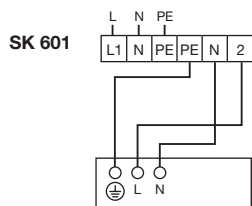

1) Wilo-TOP-S/-Z/-SD

1) Automatic restart after power failure

3) SK 622 additionally with terminals for collective run and fault signal

Circuit diagram B
Mains 1~230 V/N/50 Hz

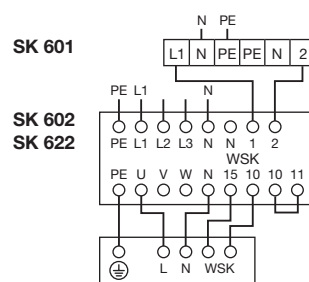

1) 3) Wilo-TOP-S/-Z/-SD

Circuit diagram C
Mains 3~400 V/N/50 Hz

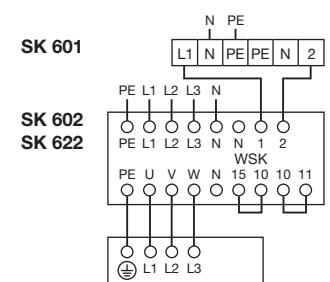

1) 3) Wilo-TOP-S/-Z/-SD

Ensure correct grounding when replacing a three-phase pump (3~400 V) with a single-phase pump (1~230 V).

Consult your Wilo representative before using Wilo pumps in conjunction with non-listed Wilo switchgears or switchgears not supplied by Wilo.

Connection Wilo-TOP... and -Stratos ... to Wilo switchgears existing on site

Circuit diagram D
Mains 3~400 V/N/50 Hz

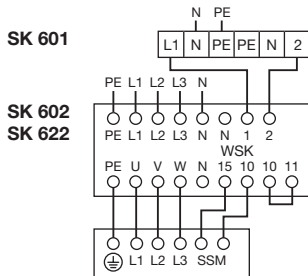

1) 2) 3) **Wilo-TOP-S/-Z/-SD**

Circuit diagram E
Mains 1~230 V/N/50 Hz

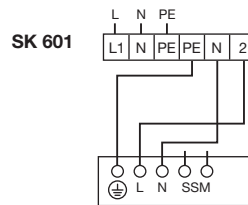

1) **Wilo-TOP-E/-ED**
Wilo-Stratos/-Z/-D

Circuit diagram F
Mains 1~230 V/N/50 Hz

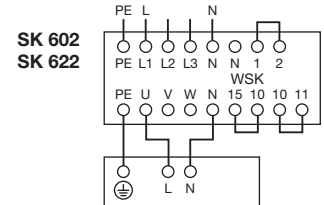

1) 3) **Wilo-TOP-S/-Z/-SD**

Circuit diagram G
Mains 3~400 V/N/50 Hz

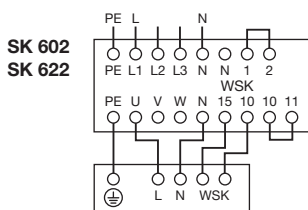

1) 3) **Wilo-TOP-S/-Z/-SD**

Circuit diagram H
Mains 3~400 V/N/50 Hz

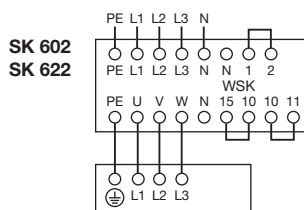

1) 2) 3) **Wilo-TOP-S/-Z/-SD**

Circuit diagram I
Mains 3~400 V/N/50 Hz

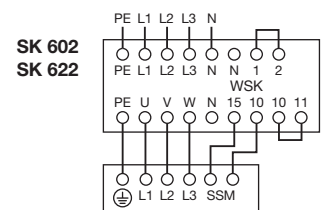

1) 2) 3) **Wilo-TOP-S/-Z/-SD**

Circuit diagram J
Mains 3~400 V/N/50 Hz
or 1~230 V/N/50 Hz

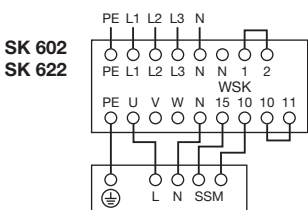

1) 2) 3) **Wilo-TOP-E/-ED**
Wilo-Stratos/-Z/-D

Circuit diagram K
Mains 3~400 V/N/50 Hz

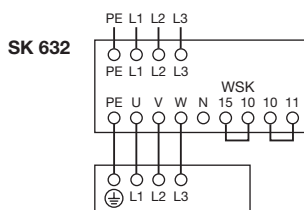

1) **Wilo-TOP-S/-Z/-SD**

Circuit diagram L
Mains 3~400 V/N/50 Hz

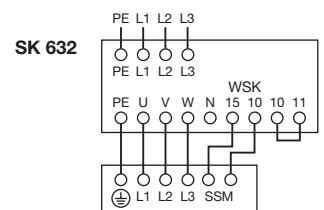

1) 2) **Wilo-TOP-S/-Z/-SD**

- 1) Automatic restart after power failure
- 2) After an overload fault trip of the pump (TOP or Stratos), reset first at the pump, then at the switchgear
- 3) SK 622 additionally with terminals for collective run and fault signal

Ensure correct grounding when replacing a three-phase pump (3~400 V) with a single-phase pump (1~230 V).

Consult your Wilo representative before using Wilo pumps in conjunction with non-listed Wilo switchgears or switchgears not supplied by Wilo.

Technical notes

Connection Wilo-TOP... and -Stratos ... to Wilo switchgears existing on site

Circuit diagram M
Mains 1~230 V/N/50 Hz

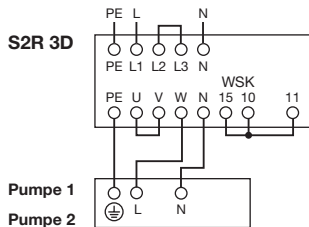

1) **Wilo-TOP-S/-Z/-SD**

Circuit diagram N
Mains 1~230 V/N/50 Hz

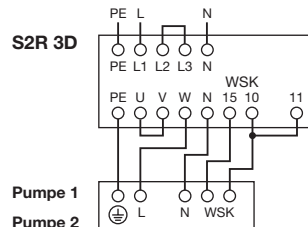

1) **Wilo-TOP-S/-Z/-SD**

Circuit diagram O
Mains 3~400 V/N/50 Hz

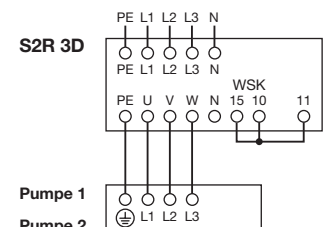

1) **Wilo-TOP-S/-Z/-SD**

Circuit diagram P
Mains 3~400 V/N/50 Hz

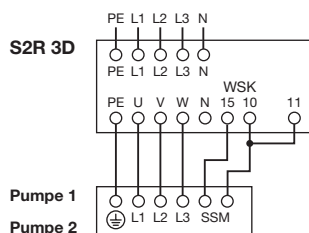

1) 2) **Wilo-TOP-S/-Z/-SD**

Circuit diagram Q
Mains 3~400 V/N/50 Hz

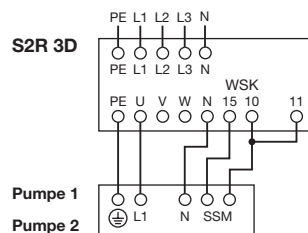

1) 2) **Wilo-TOP-E/-ED**
Wilo-Stratos/-Z/-D

Circuit diagram R
Mains 1~230 V/N/50 Hz

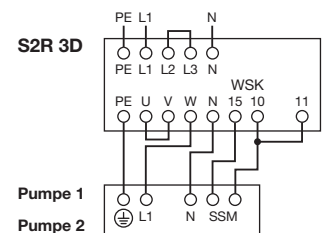

1) 2) **Wilo-TOP-E/-ED**
Wilo-Stratos/-Z/-D

Circuit diagram S
Mains 1~230 V/N/50 Hz

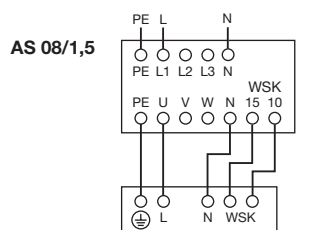

1) **Wilo-TOP-S/-Z/-SD**

Circuit diagram T
Mains 3~400 V/N/50 Hz

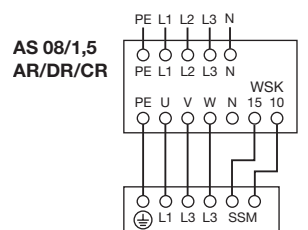

1) 2) **Wilo-TOP-S/-Z/-SD**

Circuit diagram U
Mains 1~230 V/N/50 Hz

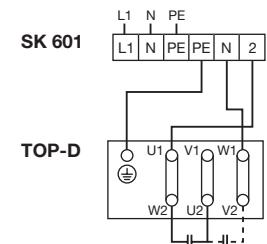

1)

- 1) Automatic restart after power failure
- 2) After an overload fault trip of the pump (TOP or Stratos), reset first at the pump, then at the switchgear

Ensure correct grounding when replacing a three-phase pump (3~400 V) with a single-phase pump (1~230 V).

Consult your Wilo representative before using Wilo pumps in conjunction with non-listed Wilo switchgears or switchgears not supplied by Wilo.

Connection Wilo-TOP... and -Stratos ... to Wilo switchgears existing on site

Circuit diagram V
Mains 1~230 V/N/50 Hz

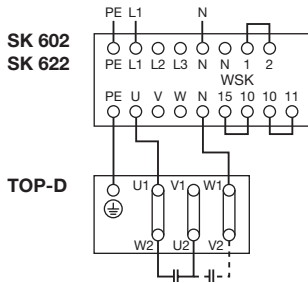

1)

Circuit diagram W
Mains 1~230 V/N/50 Hz

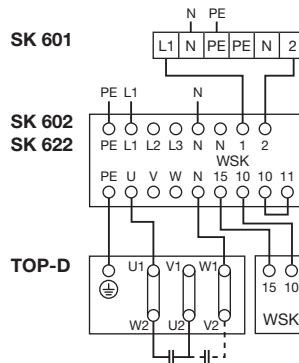

1) 3)

Circuit diagram X
Mains 1~230 V/N/50 Hz

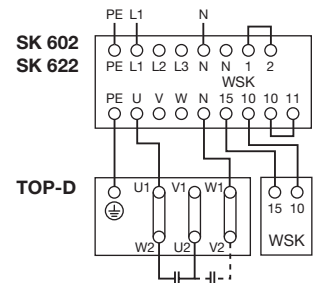

1)

Circuit diagram Y
Mains 3~400 V/N/50 Hz

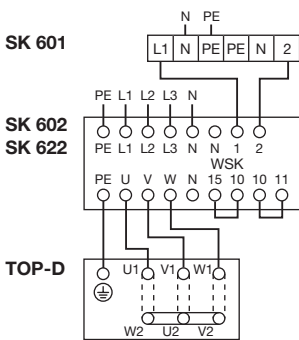

1) 3)

Circuit diagram Y1
Mains 3~400 V/N/50 Hz

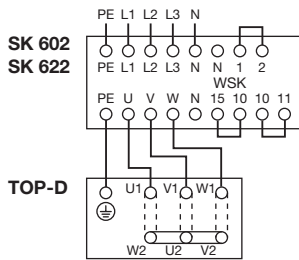

1) 3)

Circuit diagram Z
Mains 3~400 V/N/50 Hz

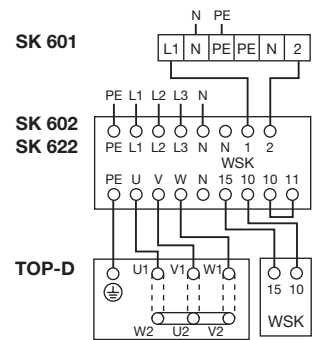

1) 3)

Circuit diagram Z1
Mains 3~400 V/N/50 Hz

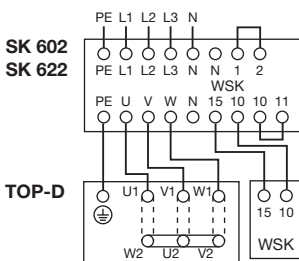

1) 3)

- 1) Automatic restart after power failure
- 3) SK 622 additionally with terminals for collective run and fault signal

Ensure correct grounding when replacing a three-phase pump (3~400 V) with a single-phase pump (1~230 V).

Consult your Wilo representative before using Wilo pumps in conjunction with non-listed Wilo switchgears or switchgears not supplied by Wilo.

Technical notes

Pump check

And in the event of faults?

High operational safety, maintenance-free operation over years, energy-saving operation and the requested low noise level are the main requirements on heating circulating pumps in technical building equipment.

Modern pumps fulfill these requirements. If however a fault occurs, it may take a long time until the cause is identified.

Pump runs

Fault	Description	Possible cause	Repair	Support
Mechanical noise	grinding, bevelling, rattling	wear of bearing, non-return flap, valve cone	change pump, avoid wobbling by changing the operating state (throttling); renew non-return flap or valve or choose different size	pump replacement list, check of the installation dimensions, the hydraulic and electrical values
	clicking	foreign matter in the pump housing or impeller	separate motor housing and pump and clean them	exchange seals, scrapers
Flow noise	gurgling	air in the installation, gas formation	venting, check pressure maintenance	automatic ventilation valves with air shut-off valve
	rushing, also in pipes	pump performance too high	check hydraulic output, measure Δp again, change flow volume by adjusting the gate valves, define correct pump performance / setpoint	differential pressure gauge, flow and return, installation thermometer
Cavitation noise	crackling	cavitation	increase static system pressure, choose pump with low inlet pressure (from pump catalogue)	increase nitrogen pressure and filling pressure in the diaphragm expansion tank
Resonance noise	humming, droning, resonating	duty point at the end of the pump curve, amplitudes too high, factor of speed multiplied with the blade number corresponds with the system components	dress impeller to size, modify immanent oscillation of the installation, choose pump with different speed	contact the Wilo service if nothing helped
Leakages	dropping between motor and pump housing	motor or can seals are faulty	change pump	heating fitter's tools
	flange or screwed seals are faulty	deformed installation, seals are too old	renew seals, attention: close gate valves of pump	scraper
Pump performance too weak	wrong direction of rotation	electrical connection wrong	wire according to installation instructions, change two phases, if it is three-phase current	insulated screwdriver
	wrong delivery direction	pressure and suction port mistaken	install pumps turned by 180° in pipework	normal fitter's tools
	suction port of the impeller is blocked	foreign matter or system dirt has been taken in	separate motor and pump housing – clean impeller, remove foreign matter, wash thoroughly	screwdriver, scribe, attention: winding must not be wet
	air in the system	water or nitrogen loss	look for cause of loss, re-fill, check diaphragm expansion vessel	filling hose with hose nozzle

Pump check

Pump runs

Fault	Description	Possible cause	Repair	Support
Pump performance too weak (continued)	motor or hand mixer closed	wrong control command	check control equipment, start mixer manually, if necessary	voltage tester, voltmeter, amperemeter, if necessary, contact control cabinet manufacturer or electrician
	speed stage too low	wrong speed stage	speed stage switch in max. position	manually or with screwdriver
	delivery head too low	wrong settings	choose higher setpoint	manually

Pump stops

Fault	Description	Possible cause	Repair	Support
Voltage at the terminal board	pump blocked	foreign matter in the impeller	separate motor and housing – remove foreign matter	screwdriver, scribe Note: winding must not be wet
		deposit in the can	deblock at the rotor shaft end	let pump run with open shaft end and flush
	rotor can be turned easily	defect capacitor	replace	insulated screwdriver
		defect winding	measure through, check passage at the terminal board, replace pump	voltage tester, voltmeter, amperemeter, normal fitter's tools
No voltage at the terminal board	protective switch or tripping unit for full motor protection has triggered	has been set too weakly	set higher, to the specified value (operating instructions)	screwdriver 2 mm and screwdriver 10 mm, for smaller and medium pump performances block rotor, switch pump on: protective switch must trigger after max. 60 s
		speed stage of pump has been modified, but no corrections at the protective switch	different protective switch installation of tripping unit for full motor protection	
		because pump is blocked	de-block	screwdriver 10 mm
		2-phase run defect MSS	check safety fuses or automat	visual check
		winding damage	change pump	normal fitter's tools
	safety fuse has triggered	short circuit, loose connection, fuses too weak, RCD, caused by control devices, control voltage at the contactor	thorough check of all possibilities	get electrical test devices or electrician

Dimensioning – heating pumps

Pump dimensioning according to demand in compliance with EnEV

The definition of the pump performance according to the actual demand is necessary if

- there have been modifications at the building, the heating system/equipment or if the utilisation has changed.
- the old pump is replaced or it has been designed too big.

In order to keep the determination of the pump performance as simple as possible, we recommend the following calculation for the rough determination of flow volume Q and delivery head H or the use of tools (PC program, pump slide rule).

This rough calculation does not replace the heat demand calculation or piping calculation for new installations.

The correct dimensioning of heating circulating pumps and the checking of the performance is compulsory even for controlled energy-saving pumps.

The following values have to be determined:

1. Heat demand \dot{Q}_N of the building
2. Flow volume \dot{V} (or Q) of the pump
3. Delivery head H of the pump

1. Heat demand \dot{Q}_N of the building

An exact calculation in accordance with DIN 4701 for residential buildings is not necessary if the specific heat demand does not exceed

- 70 W/m²** useful area of buildings or
- 100 W/m²** for free-standing buildings with max. 2 dwellings

$$\dot{Q}_N = \frac{\text{Useful area} \times \text{spec. heat demand}}{1000} \text{ [kW]}$$

Note:

If a detailed heat demand calculation is done or if exact values are available from the past, these should be used.

2. Flow volume \dot{V} (Q) depending on specific heat demand

Rough determination of flow volumes for pump dimensioning and pre-setting of thermostatic valves in heating installations

Spec. heat demand per m ² useful area	\dot{q}_{spec}	Spec. flow volume per m ² useful area at $\Delta \vartheta$			
		\dot{V}_{spec} at 20 K	\dot{V}_{spec} at 15 K	\dot{V}_{spec} at 10 K	\dot{V}_{spec} at 5 K
residential buildings with ...					
max. 2 dwellings	100 W/m ²	4.3 l/h	5.7 l/h	8.6 l/h	17.2 l/h
more than 2 dwellings	70 W/m ²	3.0 l/h	4.0 l/h	6.0 l/h	12.0 l/h
low-energy house-standard	≤ 40 W/m ²	≤ 1.7 l/h	≤ 2.3 l/h	≤ 3.4 l/h	≤ 6.8 l/h

$$Q_{\text{Pu}} = \dot{V}_{\text{Pu or TV}}$$

$$Q_{\text{Pu}} = A_N \cdot \dot{V}_{\text{spec}} \text{ [l/h]}$$

A_N The heatable useful area which is covered by the pump or the thermostatic valve [m²]

V_{spec} Specific flow volume per m² useful area at $\Delta \vartheta$

Q_{spec} Specific heat demand per m² useful area according to HeizAnIV

3. Delivery head H of the pump

(Differential pressure at flow volume)

As the calculation of the delivery head H is very complex for existing heating systems, the following simplified methods are usually sufficient when replacing pumps:

a) Global method

Reduce delivery head of the old pump generally by approx. 25 %. The thus resulting reduction of the pump performance is uncritical. Experience shows that these influences are compensated in the heating system by performances reserves in the radiator and wide open thermostatic valves.

b) Simplified calculation method

Simplification is permitted (e.g. negligence of branch pipes, etc.), as the influences on the total value are only minor.

$$\text{Pump delivery head: } H_{\text{Pu}} = \frac{R \cdot l \cdot ZF}{10.000} \text{ [m]}$$

R = 50 to 150 [Pa/m] (old building 50 ... new building 150)

l = Length of the most unfavourable branch [m] (feed + return)

ZF = Allowance factor:

Adapters/fittings/thermostatic valves = 2.2

as above, plus mixer/return flow inhibitor = 2.6

H_{Pu} = set delivery head of the pump as low as it needs for a trouble-free supply.

Only these loss values are crucial in circulation systems for the delivery head of the pump.

With the determined values for:

Volume flow rate \dot{V} (or Q) = ... m³/h and

delivery head H = ... m

the pump selection can be done with regard to the pump curves and recommendations for the dimensioning:

>Wilo catalogues

>Wilo-Select (PC-program)

Dimensioning – heating pumps

Wilo tips

Volume flow rate \dot{V} (Q) of the pump

- Select the pump type so that the determined volume flow rate is **in the right half of the pump curve.**

Delivery head H of the pump

- Set the delivery head at the pump or at a local differential pressure controller (hydraulic balancing) to max. 2 m or 20 kPa.
- Set the lowest delivery head which is sufficient for a safe heat supply, possibly determine by trial and error.
- If there are problems with the heat supply, check first the hydraulic balancing.

Use of high-efficiency and energy-saving pumps

- **Minimum differential pressure of pump**
Must be available any time in order to guarantee the heat supply to the most unfavourably connected consumer. If there is no calculation of the piping, the differential pressure is determined by trial and error.
- **Maximum differential pressure of pump**
The max. differential pressure in the secondary heating and control cycle shall not exceed 2 m or 20 kPa. If necessary, carry out the hydraulic balancing.
- **Control Δp -constant/ Δp -variable/ Δp -constant-variable**
These control modes compensate best calculation tolerances and ensure the heat supply to all consumers at lowest power consumption.

Dimensioning – secondary hot water circulating pumps

Secondary hot water circulating pumps

Simplified calculation for selecting the right secondary hot water circulating pump in one-family homes.

For a correct dimensioning of pumps in larger secondary hot water systems, the piping system has to be calculated according to DIN 1988 and W 551 to W 553. The necessary flow rate should be based on the figures recommended in the standard and the DVGW guideline.

Volume flow rate according to spec. heat demand

Rough determination of flow volumes for pump dimensioning and pre-setting of line shut-off valves in secondary hot water circulation systems

Volume flow rate of

$$Q_{PU} = \dot{V}_{PU \text{ or } SV}$$

$$Q_{PU} = l \cdot \dot{V}_{spec}$$

- l** The length of the supply pipes of the secondary hot water system with circulation pipes
- \dot{V}_{spec}** Specific volume flow rate per m pipe length at ϑ
- \dot{Q}_{spec}** Specific heat demand per m pipe length in accordance with W 553/Table 3
- PU** = Pump
- SV** = Line shut-off valve (Strangventil)

pipe	Spec. heat demand per m hot water pipe \dot{Q}_{spec}	Spec. volume flow rate per m hot water pipe at ϑ permitted temperature decrease			
		\dot{V}_{spec} at 2 K	\dot{V}_{spec} at 3 K	\dot{V}_{spec} at 4 K	\dot{V}_{spec} at 5 K
freely run in the basement/ non-heated rooms	11 W/m	4.6 l/h	3.1 l/h	2.3 l/h	1.8 l/h
run in a shaft or in the wall	7 W/m	2.9 l/h	1.9 l/h	1.5 l/h	1.2 l/h

Setting of the delivery head

$$\text{Pump delivery head: } H_{pu} = \frac{R \times l \times ZF}{10.000} \text{ [m]}$$

- R** = 50 to 500 [Pa/m]
- l** = Length of the most unfavourable line of the hot water supply [m]
- ZF** = Allowance factor: Adapters/fittings/line shut-off valves = 2.0
- H_{pu}** = set delivery head of the pump as low as it needs for a trouble-free supply.

High-efficiency circulating pump Wilo-Stratos-Z

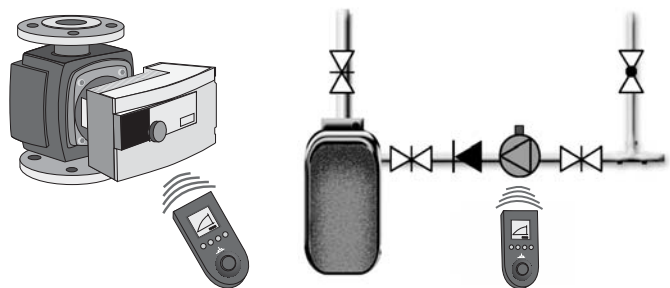

Function:

Adaptation of the pump performance to the actual demand in order to

- avoid valve noise
- reduce power consumption
- avoid flow erosions.

Note:

- If the delivery head of the pump is chosen too high $H_{pu} > 2$ m this will lead up to noise and higher power consumption.
- Two differential pressure control modes Δp -c (constant) or Δp -v (variable) are possible.

Name plates

Wilo-Stratos and Wilo-TOP

Nameplate codes for Wilo-TOP series pumps

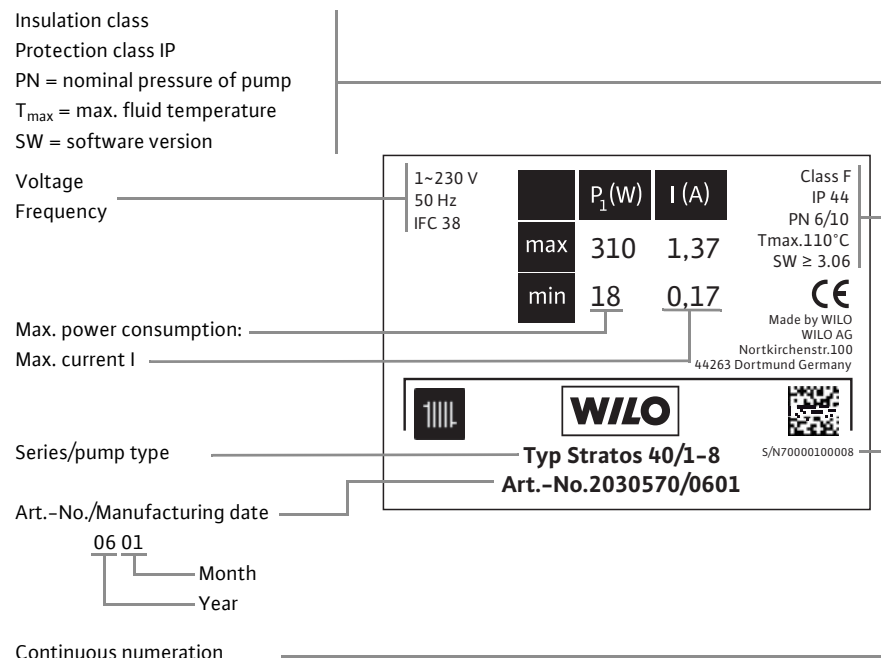

Standard version

Serial code of the Wilo-Stratos series

Type:
Wilo-...

Design

Stratos
Stratos-D
Stratos-Z

High-efficiency pumps
infinitely variable speed
controlled
Single-head pump
Twin-head pump
Single-head pump for second-
ary hot water circulation systems

Nameplate codes for Wilo-TOP series pumps

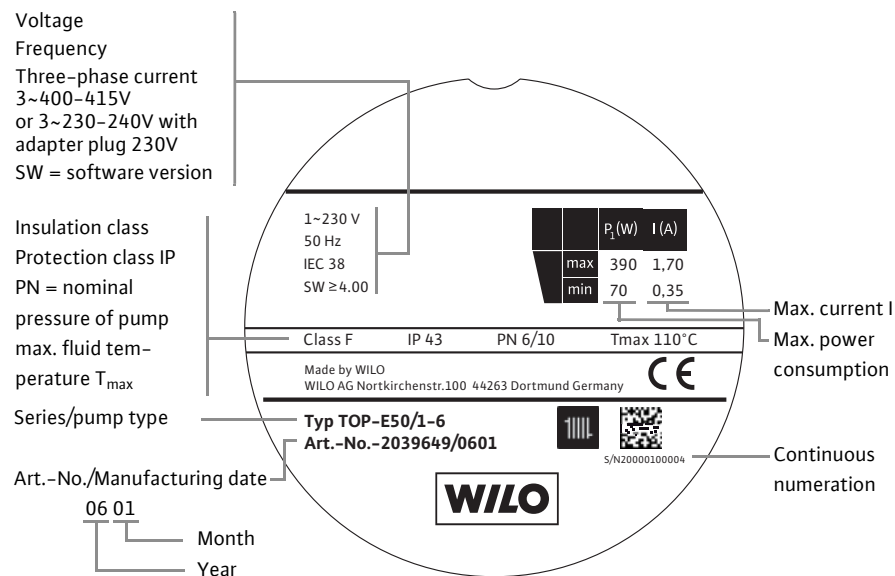

Standard version

Serial code for the Wilo-TOP series

Type:
Wilo-...

Design

TOP-E
TOP-ED

TOP-S
TOP-SD

TOP-D

TOP-S

Energy-saving pumps
infinitely variable speed
controlled
Single-head pump
Twin-head pump
Standard pumps
3 speed stages
Single-head pump
Twin-head pump
Standard pumps
1 speed stage
Single-head pump
Circulating pumps for secondary
hot water circulation systems
3 speed stages
Single-head pump

Wilo-Star, Wilo-Stratos ECO and Wilo standard program

Designation of name plate Wilo-Star, Wilo-Stratos ECO and Wilo standard program

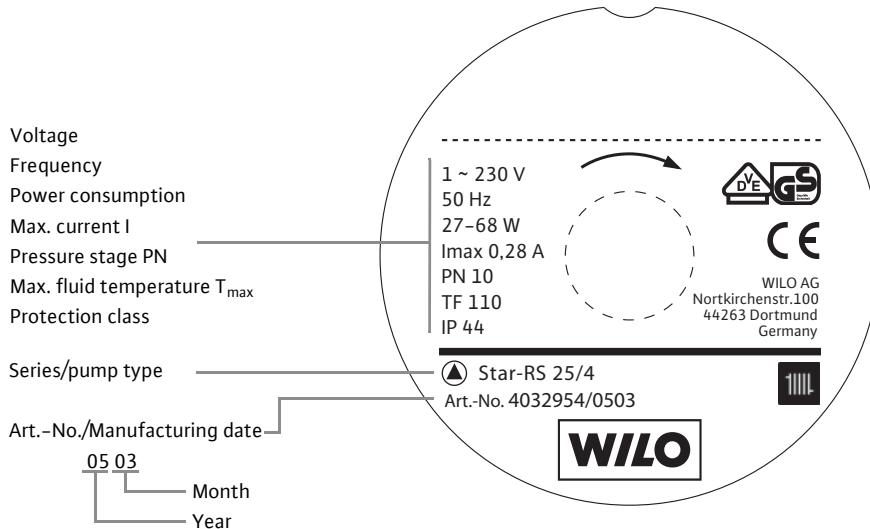

Standard version

Serial codes for the Wilo-Star, Wilo-Stratos ECO ranges and the Wilo standard program

Type:	Design
Wilo-...	High-Efficiency Pumps infinitely variable speed
Stratos ECO	Single-head pump in Economy-version for heating applications
Stratos ECO-L	Single-head pump in Economy-version for heating applications with connection for rapid ventilation
Stratos ECO ST	Single-head pump in Economy-version for solar thermal applications
	Energy-saving pumps infinitely variable speed controlled
Star-E	Single-head pump Venting pump
	Standard pumps 3 speed stages
Star-RS	Single-head pump
Star-RSD	Twin-head pump
Star-RSL	Venting pump
	Standard pumps 4 speed stages
RP, P	Single-head pump
DOP	Twin-head pump
	Secondary hot water circulating pumps
Star-Z	Single-head pumps, 1 or 3 speed stages
Stratos ECO-Z	High-efficiency pump in Economy-version for secondary hot water circulation

Non-standard versions

Some pumps can be supplied in the following design options (on request at additional costs).

The type of non-standard version is identified on the nameplate.

- **PN 10** Max. permitted operating pressure of pump 10 bar
- **RG** Red bronze version

E.g.

Star-RS 25/4 RG = Star-RS 25/4 with red bronze housing

Type key

Wilo-Star-E, Wilo-TOP-E, TOP-ED

Type key

High-efficiency pumps

Example: Wilo-Stratos 30/1-12

Stratos	Screwed-end or flange-end pump	infinitely variable electronic control
Stratos-D	Flange-end twin-head pump	infinitely variable electronic control
Stratos-Z	Screwed-end or flange-end pump for secondary hot water circulation systems	infinitely variable electronic control
Stratos ECO	Screwed-end pump in Economy-version, specially for 1-6-family homes	infinitely variable electronic control
Stratos ECO-Z	Screwed-end pump in Economy-version for secondary hot water circulation systems	infinitely variable electronic control
30/	Nominal connection diameter	
1-12	Nominal delivery head range (m)	
BMS	Version with Building Management System	
ST	Version with special hydraulics for the use in solar thermal systems	
L	Venting pump	

Energy-saving pumps

Example: Wilo-Star-E 25/1-5
Wilo-TOP-E 50/1-6

Star-E	Screwed-end pump	infinitely variable electronic control
TOP-E	Screwed-end or flange-end pump	infinitely variable electronic control
TOP-ED	Flange-end twin-head pump	infinitely variable electronic control
50/	Nominal connection diameter	
1-6	Nominal delivery head range (m)	

Standard pumps, max. 2,800 rpm

Example: Wilo-Star-RS 25/6
Wilo-TOP-S 50/4

Star-RS	Screwed-end pump	3 speed stages, manually reversible
Star-RSD	Screwed-end twin-head pump	3 speed stages, manually reversible
Star-Z	Screwed-end pump for secondary hot water circulation systems	1/3 speed stages, manually reversible
Star ST	Screwed-end pump for solar thermal	3 speed stages, manually reversible
Star-AC	Screwed-end pump for air conditioning/refrigeration	3 speed stages, manually reversible
TOP-S	Screwed-end or flange-end pump	3 speed stages, manually reversible
TOP-S	Screwed-end or flange-end pump for secondary hot water circulation systems	3 speed stages, manually reversible
TOP-SD	Flange-end twin-head pump	3 speed stages, manually reversible
25/	Nominal connection diameter	
6	Nominal delivery head (m) at $Q = 0 \text{ m}^3/\text{h}$	
EM	Version with single-phase motor	
DM	Version with three-phase motor	
L	Venting pump	

Standard pumps, max. 1,400 rpm

Example: Wilo-RP 25/80 r,
Wilo-TOP-D 40

RP	Screwed-end pump	$\frac{3}{4}$ speed stages, manually reversible
P	Flange-end pump	4 speed stages, manually reversible
TOP-D	Screwed-end or flange-end pump	1 speed stage
DOP	Flange-end twin-head pump	4 speed stages, manually reversible
25	Nominal connection diameter	
/80	Nominal impeller diameter	
r	4-stage manual switching	



Pumpen Intelligenz.

Worldwide the name Wilo is synonymous with the tradition of first class German engineering. Our pumps and pump systems for heating, air conditioning, cooling, water supply and sewage are used in all areas of public life: in commercial buildings, communal facilities, industry as well as in private homes. In close cooperation with our customers, we have over the decades further developed our know-how from pumps and beyond to system competence. This know-how is the basis for solutions which are geared towards meeting the special needs of our customers: that is what we call Pumpen Intelligenz.



Pumpen Intelligenz.

WILO AG
Nortkirchenstraße 100
44263 Dortmund
Germany
T +49 231 4102-0
F +49 231 4102-7363
www.wilo.com

Wilo – International (Subsidiaries)

Austria

WILO Handelsges. m.b.H.
1230 Wien
T +43 5 07507-0
F +43 5 07507-42
office@wilo.at

Azerbaijan

WILO Caspian LLC
1014 Baku
T +994 12 4992386
F +994 12 4992879
info@wilo.az

Belarus

WILO Bel OOO
220035 Minsk
T +375 17 2503393
F +375 17 2503383
wilobel@wilo.by

Belgium

WILO SA/NV
1083 Ganshoren
T +32 2 4823333
F +32 2 4823330
info@wilo.be

Bulgaria

WILO Bulgaria Ltd.
1125 Sofia
T +359 2 9701970
F +359 2 9701979
info@wilo.bg

Canada

WILO Canada Inc.
Calgary, Alberta T2A5L4
T/F +1 403 2769456
bill.lowe@wilo-na.com

China

WILO SALMSON (Beijing)
Pumps System Ltd.
101300 Beijing
T +86 10 80493900
F +86 10 80493788
wiloobj@wilo.com.cn

Croatia

WILO Hrvatska d.o.o.
10090 Zagreb
T +38 51 3430914
F +38 51 3430930
wilo-hrvatska@wilo.hr

Czech Republic

WILO Praha s.r.o.
25101 Cestlice
T +420 234 098 711
F +420 234 098 710
info@wilo.cz

Denmark

WILO Danmark A/S
2690 Karlslunde
T +45 70 253312
F +45 70 253316
wilo@wilo.dk

Estonia

WILO Eesti OÜ
12618 Tallinn
T +372 6509780
F +372 6509781
info@wilo.ee

Finland

WILO Finland OY
02330 Espoo
T +358 207401540
F +358 207401549
wilo@wilo.fi

France

WILO S.A.S.
78310 Coignières
T +33 1 30050930
F +33 1 34614959
info@wilo.fr

Great Britain

WILO (U.K.) Ltd.
DE14 2WJ Burton-
Upon-Trent
T +44 1283 523000
F +44 1283 523099
sales@wilo.co.uk

Greece

WILO Hellas AG
14569 Anixi (Attika)
T +302 10 6248300
F +302 10 6248360
wilo.info@wilo.gr

Hungary

WILO Magyarország Kft
2045 Törökbálint
(Budapest)
T +36 23 889500
F +36 23 889599
wilo@wilo.hu

Ireland

WILO Engineering Ltd.
Limerick
T +353 61 227566
F +353 61 229017
sales@wilo.ie

Italy

WILO Italia s.r.l.
20068 Peschiera
Borromeo (Milano)
T +39 25538351
F +39 255303374
wilo.italia@wilo.it

Kazakhstan

WILO Central Asia
050002 Almaty
T +7 3272 785961
F +7 3272 785960
in.pak@wilo.kz

Korea

WILO Pumps Ltd.
621-807 Gimhae
Gyeongnam
T +82 55 3405809
F +82 55 3405885
wilo@wilo.co.kr

Latvia

WILO Baltic SIA
1019 Riga
T +371 7 145229
F +371 7 145566
mail@wilo.lv

Lebanon

WILO SALMSON
Lebanon
12022030 El Metn
T +961 4 722280
F +961 4 722285
wsl@cyberia.net.lb

Lithuania

WILO Lietuva UAB
03202 Vilnius
T/F +370 2 236495
mail@wilo.lt

Montenegro

WILO Beograd d.o.o.
11000 Beograd
T +381 11 2850410
F +381 11 2851278
office@wilo.co.yu

The Netherlands

WILO Nederland b.v.
1948 RC Beverwijk
T +31 251 220844
F +31 251 225168
info@wilo.nl

Norway

WILO Norge AS
0901 Oslo
T +47 22 804570
F +47 22 804590
wilo@wilo.no

Poland

WILO Polska Sp. z o.o.
05-090 Raszyn
T +48 22 7026161
F +48 22 7026100
wilo@wilo.pl

Portugal

Bombas Wilo-Salmson
Portugal Lda.
4050-040 Porto
T +351 22 2076900
F +351 22 2001469
bombas@wilo-salmson.pt

Romania

WILO Romania s.r.l.
041833 Bucharest
T +40 21 4600612
F +40 21 4600743
wilo@wilo.ro

Russia

WILO Rus ooo
123592 Moscow
T +7 495 7810690
F +7 495 7810691
wilo@orc.ru

Serbia

WILO Beograd d.o.o.
11000 Beograd
T +381 11 2850410
F +381 11 2851278
office@wilo.co.yu

Slovakia

WILO Slovakia s.r.o.
82008 Bratislava 28
T +421 2 45520122
F +421 2 45246471
wilo@wilo.sk

Slovenia

WILO Adriatic d.o.o.
1000 Ljubljana
T +386 1 5838130
F +386 1 5838138
wilo.adriatic@wilo.si

Spain

WILO Ibérica S.A.
28806 Alcalá de Henares
(Madrid)
T +34 91 8797100
F +34 91 8797101
wilo.iberica@wilo.es

Sweden

WILO Sverige AB
35246 Växjö
T +46 470 727600
F +46 470 727644
wilo@wilo.se

Switzerland

EMB Pumpen AG
4310 Rheinfelden
T +41 61 8368020
F +41 61 8368021
info@emb-pumpen.ch

Turkey

WILO Pompa Sistemleri
San. ve Tic. A.Ş.
34857 Istanbul
T +90 216 6610203
F +90 216 6610212
wilo@wilo.com.tr

Ukraine

WILO Ukraina t.o.w.
01033 Kiev
T +38 044 2011870
F +38 044 2011877
wilo@wilo.ua

USA

WILO-EMU LLC
Thomasville, Georgia
31758-7810
T +1 229 584 0098
F +1 229 584 0234
terry.rouse@wilo-emu.com

USA

WILO USA LLC
Calgary, Alberta T2A5L4
T/F +1 403 2769456
bill.lowe@wilo-na.com

Wilo – International (Representation offices)

Bosnia and Herzegovina

71000 Sarajevo
T +387 33 714510
F +387 33 714511
zeljko.cvjetkovic@wilo.ba

Georgia

0177 Tbilisi
T/F +995 32317813
info@wilo.ge

Macedonia

1000 Skopje
T/F +389 2122058
valerij.vojneski@wilo.com.mk

Moldova

2012 Chisinau
T/F +373 2 223501
sergiu.zagurean@wilo.md

Tajikistan

Dushanbe
T +992 93 5554541

Uzbekistan

100046 Taschkent
T/F +998 71 1206774
info@wilo.uz

August 2006